

SCXI™

Getting Started with SCXI

Worldwide Technical Support and Product Information

www.ni.com

National Instruments Corporate Headquarters

11500 North Mopac Expressway Austin, Texas 78759-3504 USA Tel: 512 794 0100

Worldwide Offices

Australia 03 9879 5166, Austria 0662 45 79 90 0, Belgium 02 757 00 20, Brazil 011 284 5011,
Canada (Calgary) 403 274 9391, Canada (Ontario) 905 785 0085, Canada (Québec) 514 694 8521,
China 0755 3904939, Denmark 45 76 26 00, Finland 09 725 725 11, France 01 48 14 24 24,
Germany 089 741 31 30, Greece 30 1 42 96 427, Hong Kong 2645 3186, India 91805275406,
Israel 03 6120092, Italy 02 413091, Japan 03 5472 2970, Korea 02 596 7456, Mexico (D.F.) 5 280 7625,
Mexico (Monterrey) 8 357 7695, Netherlands 0348 433466, New Zealand 09 914 0488, Norway 32 27 73 00,
Poland 0 22 528 94 06, Portugal 351 1 726 9011, Singapore 2265886, Spain 91 640 0085,
Sweden 08 587 895 00, Switzerland 056 200 51 51, Taiwan 02 2528 7227, United Kingdom 01635 523545

For further support information, see the *Technical Support Resources* appendix. To comment on the documentation, send e-mail to techpubs@ni.com

© Copyright 1993, 2000 National Instruments Corporation. All rights reserved.

Important Information

Warranty

SCXI devices are warranted against defects in materials and workmanship for a period of one year from the date of shipment, as evidenced by receipts or other documentation. National Instruments will, at its option, repair or replace equipment that proves to be defective during the warranty period. This warranty includes parts and labor.

The media on which you receive National Instruments software are warranted not to fail to execute programming instructions, due to defects in materials and workmanship, for a period of 90 days from date of shipment, as evidenced by receipts or other documentation. National Instruments will, at its option, repair or replace software media that do not execute programming instructions if National Instruments receives notice of such defects during the warranty period. National Instruments does not warrant that the operation of the software shall be uninterrupted or error free.

A Return Material Authorization (RMA) number must be obtained from the factory and clearly marked on the outside of the package before any equipment will be accepted for warranty work. National Instruments will pay the shipping costs of returning to the owner parts which are covered by warranty.

National Instruments believes that the information in this document is accurate. The document has been carefully reviewed for technical accuracy. In the event that technical or typographical errors exist, National Instruments reserves the right to make changes to subsequent editions of this document without prior notice to holders of this edition. The reader should consult National Instruments if errors are suspected. In no event shall National Instruments be liable for any damages arising out of or related to this document or the information contained in it.

EXCEPT AS SPECIFIED HEREIN, NATIONAL INSTRUMENTS MAKES NO WARRANTIES, EXPRESS OR IMPLIED, AND SPECIFICALLY DISCLAIMS ANY WARRANTY OF MERCHANTABILITY OR FITNESS FOR A PARTICULAR PURPOSE. CUSTOMER'S RIGHT TO RECOVER DAMAGES CAUSED BY FAULT OR NEGLIGENCE ON THE PART OF NATIONAL INSTRUMENTS SHALL BE LIMITED TO THE AMOUNT THEREOF PAID BY THE CUSTOMER. NATIONAL INSTRUMENTS WILL NOT BE LIABLE FOR DAMAGES RESULTING FROM LOSS OF DATA, PROFITS, USE OF PRODUCTS, OR INCIDENTAL OR CONSEQUENTIAL DAMAGES, EVEN IF ADVISED OF THE POSSIBILITY THEREOF. This limitation of the liability of National Instruments will apply regardless of the form of action, whether in contract or tort, including negligence. Any action against National Instruments must be brought within one year after the cause of action accrues. National Instruments shall not be liable for any delay in performance due to causes beyond its reasonable control. The warranty provided herein does not cover damages, defects, malfunctions, or service failures caused by owner's failure to follow the National Instruments installation, operation, or maintenance instructions; owner's modification of the product; owner's abuse, misuse, or negligent acts; and power failure or surges, fire, flood, accident, actions of third parties, or other events outside reasonable control.

Copyright

Under the copyright laws, this publication may not be reproduced or transmitted in any form, electronic or mechanical, including photocopying, recording, storing in an information retrieval system, or translating, in whole or in part, without the prior written consent of National Instruments Corporation.

Trademarks

ComponentWorks™, CVI™, DAQCard™, DAQPad™, LabVIEW™, National Instruments™, ni.com™, NI-DAQ™, PXI™, RTSI™, SCXI™, and VirtualBench™ are trademarks of National Instruments Corporation.

ICP® is a registered trademark of PCB Piezotronics, Inc. Other product and company names mentioned herein are trademarks or trade names of their respective companies.

WARNING REGARDING USE OF NATIONAL INSTRUMENTS PRODUCTS

(1) NATIONAL INSTRUMENTS PRODUCTS ARE NOT DESIGNED WITH COMPONENTS AND TESTING FOR A LEVEL OF RELIABILITY SUITABLE FOR USE IN OR IN CONNECTION WITH SURGICAL IMPLANTS OR AS CRITICAL COMPONENTS IN ANY LIFE SUPPORT SYSTEMS WHOSE FAILURE TO PERFORM CAN REASONABLY BE EXPECTED TO CAUSE SIGNIFICANT INJURY TO A HUMAN.

(2) IN ANY APPLICATION, INCLUDING THE ABOVE, RELIABILITY OF OPERATION OF THE SOFTWARE PRODUCTS CAN BE IMPAIRED BY ADVERSE FACTORS, INCLUDING BUT NOT LIMITED TO FLUCTUATIONS IN ELECTRICAL POWER SUPPLY, COMPUTER HARDWARE MALFUNCTIONS, COMPUTER OPERATING SYSTEM SOFTWARE FITNESS, FITNESS OF COMPILERS AND DEVELOPMENT SOFTWARE USED TO DEVELOP AN APPLICATION, INSTALLATION ERRORS, SOFTWARE AND HARDWARE COMPATIBILITY PROBLEMS, MALFUNCTIONS OR FAILURES OF ELECTRONIC MONITORING OR CONTROL DEVICES, TRANSIENT FAILURES OF ELECTRONIC SYSTEMS (HARDWARE AND/OR SOFTWARE), UNANTICIPATED USES OR MISUSES, OR ERRORS ON THE PART OF THE USER OR APPLICATIONS DESIGNER (ADVERSE FACTORS SUCH AS THESE ARE HEREAFTER COLLECTIVELY TERMED "SYSTEM FAILURES"). ANY APPLICATION WHERE A SYSTEM FAILURE WOULD CREATE A RISK OF HARM TO PROPERTY OR PERSONS (INCLUDING THE RISK OF BODILY INJURY AND DEATH) SHOULD NOT BE RELIANT SOLELY UPON ONE FORM OF ELECTRONIC SYSTEM DUE TO THE RISK OF SYSTEM FAILURE. TO AVOID DAMAGE, INJURY, OR DEATH, THE USER OR APPLICATION DESIGNER MUST TAKE REASONABLY PRUDENT STEPS TO PROTECT AGAINST SYSTEM FAILURES, INCLUDING BUT NOT LIMITED TO BACK-UP OR SHUT DOWN MECHANISMS. BECAUSE EACH END-USER SYSTEM IS CUSTOMIZED AND DIFFERS FROM NATIONAL INSTRUMENTS' TESTING PLATFORMS AND BECAUSE A USER OR APPLICATION DESIGNER MAY USE NATIONAL INSTRUMENTS PRODUCTS IN COMBINATION WITH OTHER PRODUCTS IN A MANNER NOT EVALUATED OR CONTEMPLATED BY NATIONAL INSTRUMENTS, THE USER OR APPLICATION DESIGNER IS ULTIMATELY RESPONSIBLE FOR VERIFYING AND VALIDATING THE SUITABILITY OF NATIONAL INSTRUMENTS PRODUCTS WHENEVER NATIONAL INSTRUMENTS PRODUCTS ARE INCORPORATED IN A SYSTEM OR APPLICATION, INCLUDING, WITHOUT LIMITATION, THE APPROPRIATE DESIGN, PROCESS AND SAFETY LEVEL OF SUCH SYSTEM OR APPLICATION.

Contents

About This Manual

Conventions Used in This Guide	xv
Related Documentation.....	xvii

Chapter 1

Introduction to SCXI

What You Need to Get Started	1-3
Identifying Your SCXI Components	1-3
SCXI Chassis.....	1-4
SCXI Modules	1-5
SCXI Terminal Blocks	1-7
Connector-and-Shell Assemblies	1-13
DAQ Plug-In Devices and PC Cards.....	1-13
DAQ Modules	1-13
SCXI Cable Assemblies	1-14
SCXI Multichassis System with Plug-In DAQ Device.....	1-14
Optional Software.....	1-15
Overview of SCXI Operation	1-17
Analog Input Modules	1-17
Analog and Digital Output Modules	1-19

Chapter 2

Installing SCXI Modules and Connecting the SCXI System to the DAQ Device

Installing Your Software.....	2-1
Installing Your DAQ Device	2-2
Installing Your SCXI Modules	2-2
Connecting the SCXI System to the DAQ Device or Computer.....	2-2
Using the Parallel Port.....	2-2
Using a Plug-in DAQ Device or DAQCard	2-2
Using an RS-232 or RS-485 Serial Port	2-6

Chapter 3

Configuring Your SCXI Hardware and Software

Module Configuration	3-1
Analog Modules	3-2
Ground-Referenced and Floating Signal Sources	3-3
SCXI-1100 Module	3-4
SCXI-1102/B/C Module	3-7
SCXI-1104/C Module	3-8
SCXI-1112 Module	3-8
SCXI-1120/D Module	3-8
SCXI-1121 Module	3-14
SCXI-1122 Module	3-23
Current-Loop Receivers	3-25
Scanning Techniques	3-25
SCXI-1124 Module	3-26
SCXI-1125 Module	3-28
SCXI-1126 Module	3-29
SCXI-1140 Module	3-29
DAQ Device Connections in Multiple-Module Systems	3-29
User-Configurable Jumpers and DIP Switches	3-29
SCXI-1141, SCXI-1142, and SCXI-1143 Modules	3-32
SCXI-1520 Module	3-34
SCXI-1530/1531 Module	3-35
SCXI-1540 Module	3-36
Digital SCXI Modules	3-36
Communication Modes	3-37
Serial Mode	3-37
Parallel Mode	3-37
SCXI-1160 Module	3-38
SCXI-1161 Module	3-38
SCXI-1162 Module	3-39
SCXI-1162HV Module	3-42
SCXI-1163 Module	3-44
SCXI-1163R Module	3-47
SCXI-1200 Module	3-50
Parallel Port Interface	3-50
Module Configuration	3-51
Analog I/O Configuration	3-51
Analog Output Configuration	3-52
Analog Input Configuration	3-52
Analog Input Polarity and Range Configuration	3-54

SCXI-1180 Feedthrough Panel.....	3-56
SCXI-1181 Breadboard Module.....	3-56
SCXI-2400 Serial Communications Module.....	3-56
Baud Rate and Address Configuration.....	3-57
SCXI Chassis	3-58
SCXI-2000 Chassis with Serial Communications.....	3-58
Baud Rate and Address Configuration.....	3-58
SCXI-1000, SCXI-1000DC, and SCXI-1001 Chassis	3-58
Configure Your Software for Use with SCXI Products	3-59
Example Programs.....	3-59

Chapter 4

Connecting and Using Accessories and Transducers

Connecting Signal Wires to the SCXI System	4-1
SCXI-13XX Terminal Blocks	4-4
TBX Terminal Blocks	4-4
Onboard Temperature Sensors for Cold-Junction Compensation.....	4-5
Opening the SCXI-13XX Terminal Block.....	4-6
Connector-and-Shell Assemblies	4-7
Connecting Transducers to the SCXI System.....	4-7
Thermocouples	4-7
Using Thermocouples with the SCXI-1100.....	4-7
Using Thermocouples with the SCXI-1102.....	4-8
Using Thermocouples with the SCXI-1112, SCXI-1120, SCXI-1121, SCXI-1122, and SCXI-1125.....	4-8
Noise and Filtering.....	4-9
Strain Gauges.....	4-9
RTDs.....	4-19
Excitation Channel Signal Connections on the SCXI-1122	4-22
Analog Circuitry in the SCXI-1122	4-23
Analog Input Channels.....	4-24
Excitation Output Channels	4-25
Analog Output Channel Signal Connections on the SCXI-1124	4-28
Chassis Ground Connections.....	4-31
LVDTs, RVDTs, and Resolvers	4-31
Connecting to LVDTs and RVDTs.....	4-32
Synchronizing Channels	4-33
Connecting to Resolvers	4-35

Appendix A

SCXI Troubleshooting and Common Questions

Appendix B

Technical Support Resources

Glossary

Index

Figures

Figure 1-1.	SCXI Systems	1-2
Figure 1-2.	SCXI System Components	1-4
Figure 1-3.	SCXI Chassis Signal Routing	1-5
Figure 1-4.	Terminal Block Options.....	1-8
Figure 1-5.	Multichassis SCXI System with Shielded Cabling.....	1-15
Figure 1-6.	The Relationship Between the Programming Environment, NI-DAQ, and the DAQ Hardware	1-16
Figure 1-7.	SCXI Signal Routing	1-18
Figure 2-1.	Attaching the SCXI Cable Assembly to the SCXI Module and Chassis	2-4
Figure 3-1.	Removing the SCXI Module Grounding Screw	3-1
Figure 3-2.	Removing the SCXI Module Cover.....	3-2
Figure 3-3.	Scanning Techniques	3-26
Figure 3-4.	SCXI-1200 Front Connector Pin Assignments.....	3-55
Figure 3-5.	SCXI-2400 Module Default Switch Settings.....	3-57
Figure 4-1.	TBX Terminal Block Cabled to an SCXI Module.....	4-4
Figure 4-2.	Removing the Terminal Block Grounding Screw	4-6
Figure 4-3.	Removing the Terminal Block Cover	4-6
Figure 4-4.	Connecting the Half-Bridge Strain Gauge to Channel 1 of the SCXI-1321 Terminal Block.....	4-10
Figure 4-5.	Quarter-Bridge Configurations	4-12
Figure 4-6.	Half-Bridge Configurations	4-13
Figure 4-7.	Full-Bridge Configurations.....	4-14
Figure 4-8.	SCXI-1520 to SCXI-1314 Quarter-Bridge Connection.....	4-16
Figure 4-9.	SCXI-1520 to SCXI-1314 Half-Bridge Connection.....	4-17
Figure 4-10.	SCXI-1520 to SCXI-1314 Full-Bridge Connection	4-18

Figure 4-11.	Connecting a Four-Wire Platinum RTD to Channel 1 of the SCXI-1320	4-20
Figure 4-12.	SCXI-1121 RTD Configurations.....	4-21
Figure 4-13.	Connecting a Quarter-Bridge Strain Gauge to Channel 0.....	4-23
Figure 4-14.	Series Connection with Current Excitation	4-27
Figure 4-15.	Four-Wire Scan Connection with Multiplexed Current Excitation	4-27
Figure 4-16.	DAC Channel Connection as Voltage Output.....	4-29
Figure 4-17.	DAC Channel Connection as Current Output, Internal Loop Supply.....	4-29
Figure 4-18.	DAC Channel Connection as Current Output, External Loop Supply.....	4-30
Figure 4-19.	Current Loop Connection, Load and External Supply Both Grounded	4-31
Figure 4-20.	4-Wire Connection	4-32
Figure 4-21.	5-Wire Connection	4-32
Figure 4-22.	Synchronizing Multiple Channels	4-34
Figure 4-23.	Interfacing to a Resolver	4-35

Tables

Table 1-1.	SCXI Modules	1-6
Table 1-2.	Direct-Mount Terminal Blocks	1-9
Table 1-3.	TBX Terminal Blocks for SCXI	1-12
Table 1-4.	SCXI Cable Assemblies	1-14
Table 3-1.	SCXI-1100 Input Signal Referencing Jumper Configurations.....	3-5
Table 3-2.	SCXI-1100 Filtering Jumper Configuration.....	3-6
Table 3-3.	SCXI-1100 PGIA Output Referencing Jumper Configuration	3-7
Table 3-4.	Gain Jumper Allocation.....	3-9
Table 3-5.	Gain Jumper Positions.....	3-10
Table 3-6.	SCXI-1120 Filter Jumper Allocation	3-11
Table 3-7.	SCXI-1120D Filter Jumper Allocation	3-12
Table 3-8.	SCXI-1120/D Signal Referencing Jumper Configuration.....	3-14
Table 3-9.	SCXI-1121 First-Stage and Second-Stage Gain Jumper Configuration.....	3-16
Table 3-10.	SCXI-1121 Gain Jumper Configuration.....	3-16
Table 3-11.	SCXI-1121 First-Stage and Second-Stage Filter Jumper Configuration.....	3-17
Table 3-12.	SCXI-1121 Excitation Mode Jumper Configuration.....	3-18
Table 3-13.	SCXI-1121 Excitation Level Jumper Configuration.....	3-20
Table 3-14.	SCXI-1121 Maximum Load per Excitation Channel.....	3-21
Table 3-15.	SCXI-1121 Half-Bridge Completion Network Jumper Configuration.....	3-22

Table 3-16.	SCXI-1121 Amplifier Output Referencing Jumper Configuration	3-23
Table 3-17.	SCXI-1122 Digital Signal Jumper Configurations	3-24
Table 3-18.	SCXI-1122 Analog Jumper Configuration	3-25
Table 3-19.	SCXI-1124 Chassis Jumper Configuration.....	3-27
Table 3-20.	SCXI-1124 Device-Type Jumper Configuration	3-28
Table 3-21.	SCXI-1140 Signal Referencing Jumper Configuration	3-30
Table 3-22.	SCXI-1140 Instrumentation Amplifier Jumper Configuration	3-31
Table 3-23.	SCXI-1140 Gain Switches for Each Channel.....	3-31
Table 3-24.	SCXI-1140 Switch Settings for Gain Selection.....	3-32
Table 3-25.	SCXI-1141/1142/1143 Chassis Jumper Configuration	3-33
Table 3-26.	SCXI-1141/1142/1143 Grounding and Shielding Jumper Configuration	3-34
Table 3-27.	NI-DAQ Functions Applicable to the SCXI-1520.....	3-35
Table 3-28.	SCXI-1160 Device-Type Configuration.....	3-38
Table 3-29.	SCXI-1161 Device-Type Configuration.....	3-39
Table 3-30.	SCXI-1162 Communication Mode Configuration.....	3-40
Table 3-31.	SCXI-1162 Parallel Lines Jumper Configuration.....	3-41
Table 3-32.	SCXI-1162 Device-Type Jumper Configuration	3-42
Table 3-33.	SCXI-1162HV Jumper Configuration	3-43
Table 3-34.	SCXI-1163 Device-Type Jumper Configuration	3-45
Table 3-35.	SCXI-1163 Mode Jumper Configuration.....	3-46
Table 3-36.	SCXI-1163R Device-Type Jumper Configuration	3-48
Table 3-37.	SCXI-1163R Chassis and Mode Jumper Configuration	3-49
Table 3-38.	SCXI-1200 Analog I/O Settings	3-51
Table 3-39.	SCXI-1200 Analog Input Configurations	3-52
Table 3-40.	SCXI-1200 Jumper Configuration.....	3-54
Table 4-1.	SCXI Module and Connector Compatibility	4-1
Table 4-2.	TBX Terminal Block Compatibility with SCXI Modules	4-5
Table 4-3.	Excitation Voltage Ranges for Configuration and Gauge Resistances.....	4-15
Table 4-4.	SCXI-1122 Maximum Load per Excitation Channel	4-22
Table 4-5.	Sense and Current Output Channel Associations	4-24
Table 4-6.	Pros and Cons of Two-Wire and Four-Wire Connections with Current-Excited Transducers	4-28
Table A-1.	Onboard Resources Reserved by SCXI.....	A-5

About This Manual

This guide is a beginner's handbook to the installation, configuration, and use of the National Instruments Signal Conditioning eXtensions for Instrumentation (SCXI) chassis, modules, and associated data acquisition (DAQ) devices. This guide is an introduction to SCXI, not a complete reference. Advanced users should refer to the appropriate hardware and software manuals for further information.

Conventions Used in This Guide

The following conventions are used in this guide.



The ♦ symbol indicates that the following text applies only to a specific product, a specific operating system, or a specific software version.



This icon denotes a note, which alerts you to important information.



This icon denotes a caution, which advises you of precautions to take to avoid injury, data loss, or a system crash.



This icon denotes a warning, which advises you of precautions to take to avoid being electrically shocked.

AI device

Refers to analog input devices that have *AI* in their names, such as the AT-AI-16XE-10.

AT E Series devices

These AT devices have an *E*- toward the ends of their names, such as the AT-MIO-16DE-10 and AT-AI-16XE-10.

bold

Bold text denotes items that you must select or click on in the software, such as menu items and dialog box options. Bold text also denotes parameter names.

DAQCard E Series devices

Refers to the DAQCard-AI-16E-4 and DAQCard-AI-16XE-50.

DIO-24

Refers to the PC-DIO-24, DAQCard-DIO-24, and PCI-6503.

DIO-96

Refers to the PC-DIO-96/PnP, PCI-DIO-96, PCI-6508, PXI-6508, or DAQPad-6508.

DIO device	Refers to any digital I/O devices, such as the PC-DIO-96/PnP PCI-DIO-32HS, or PXI-6533.
<i>italic</i>	Italic text denotes variables, emphasis, a cross reference, or an introduction to a key concept. This font also denotes text that is a placeholder for a word or value that you must supply.
Lab/1200 device	Refers to the DAQCard-1200, DAQPad-1200, Lab-PC+, Lab-PC-1200, Lab-PC-1200AI, SCXI-1200, and PCI-1200.
MIO device	Refers to the multifunction I/O devices.
MIO-16D	Refers to the AT-MIO-16DE-10.
monospace	Text in this font denotes text or characters that you should enter from the keyboard, sections of code, programming examples, and syntax examples. This font is also used for the proper names of disk drives, paths, directories, programs, subprograms, subroutines, device names, functions, operations, variables, filenames and extensions, and code excerpts.
NI-DAQ	Refers to the NI-DAQ driver software unless otherwise noted.
PXI	Refers to PCI eXtensions for Instrumentation and is derived from the CompactPCI Standard.
Remote SCXI	Refers to an SCXI configuration where either an SCXI-2000 chassis or an SCXI-2400 remote communications module is connected to the serial port of your computer.
SCXI analog input module	Refers to the SCXI-1100, SCXI-1102/B/C, SCXI-1104/C, SCXI-1112, SCXI-1120/D, SCXI-1121, SCXI-1122, SCXI-1125, SCXI-1126, SCXI-1140, SCXI-1141, SCXI-1142, SCXI-1143, SCXI-1520, SCXI-1530/1531, and SCXI-1540.
SCXI analog output module	Refers to the SCXI-1124.
SCXI chassis	Refers to the SCXI-1000, SCXI-1000DC, SCXI-1001, and SCXI-2000.
SCXI communication module	Refers to the SCXI-2400.
SCXI digital module	Refers to the SCXI-1160, SCXI-1161, SCXI-1162, SCXI-1162HV, SCXI-1163, and SCXI-1163R.
SCXI DAQ module	Refers to the SCXI-1200.

Related Documentation

As you read this manual, you may find it helpful to refer to the following documents:

- Your SCXI chassis, module, terminal block, connector-and-shell, and cable assembly user manuals or installation guides
- Your DAQ hardware user manual
- Your National Instruments software manuals
- Application notes

Introduction to SCXI

This chapter gives a brief overview of SCXI and helps you identify the components of an SCXI system.

Figure 1-1 shows how you can use the flexible architecture of SCXI in three ways—as a front-end signal conditioning system for plug-in DAQ devices, or as an external DAQ system that attaches either directly to the computer parallel port or an RS-232 or RS-485 serial port.

Figure 1-1a shows SCXI products as a front-end signal conditioning system for plug-in DAQ devices. The SCXI chassis can house a variety of signal conditioning modules. Analog input signals are conditioned and passed to a single plug-in DAQ device for analog-to-digital conversion. The plug-in DAQ device also controls and monitors the operation of digital I/O and analog output modules in the SCXI system. You can monitor and control up to 3,072 signals with a single plug-in DAQ device.

Figure 1-1b shows an SCXI-1200 DAQ module with which you can condition and digitize your signals in the SCXI itself. The 12-bit SCXI-1200 module in an SCXI chassis digitizes the conditioned analog input signals and transmits the digital data to the computer parallel port.

Figure 1-1c shows an SCXI system that uses an SCXI-2000 or SCXI-2400 to transmit data digitized by an SCXI-1200 to the computer using an RS-232 or RS-485 serial connection. If you use an RS-485, you can connect multiple SCXI chassis within a single network. If you use an SCXI chassis without any analog input modules, you do not need an SCXI-1200 module in that chassis.

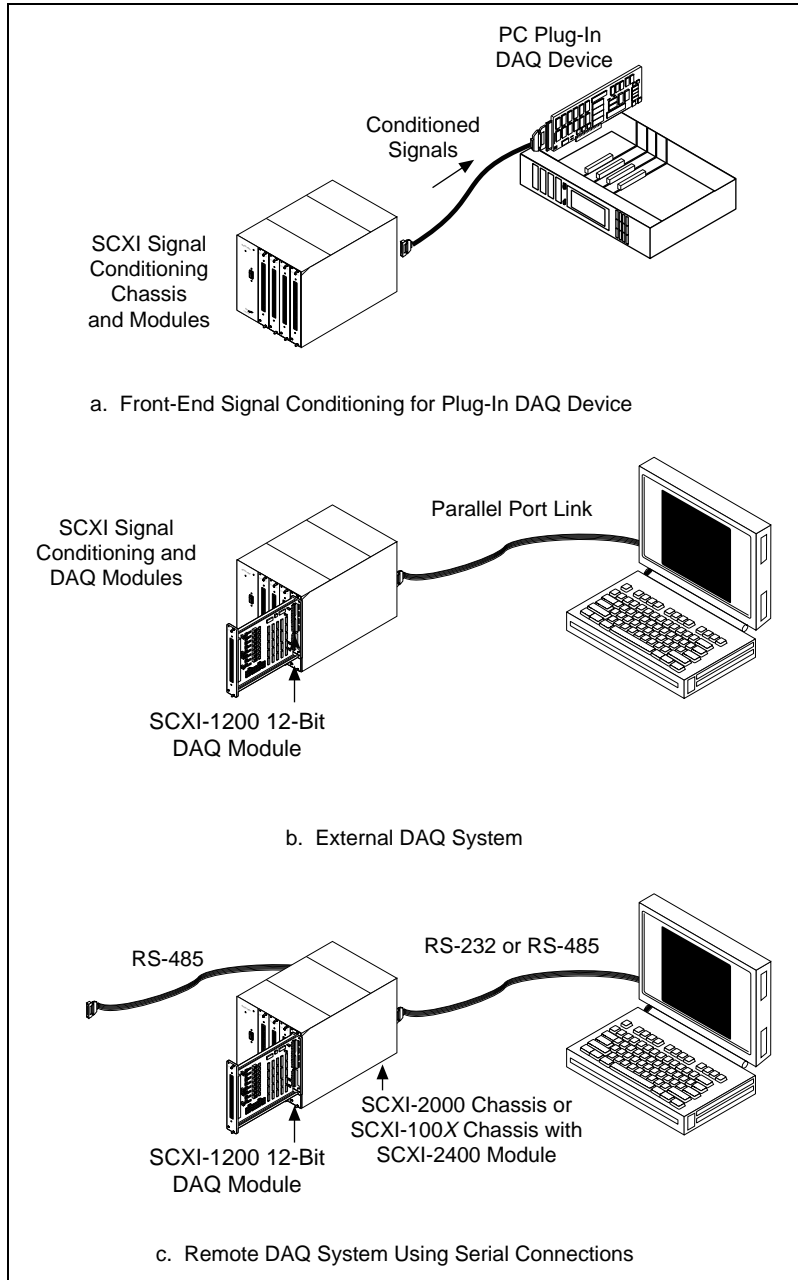

Figure 1-1. SCXI Systems

What You Need to Get Started

To set up and use your SCXI system, you will need the following:

- One of the following chassis and your SCXI chassis user manual:
 - SCXI-1000
 - SCXI-1000DC
 - SCXI-1001
 - SCXI-2000
- SCXI modules and terminal blocks to use in your chassis
- SCXI-1200 DAQ module or DAQ device (if using any analog input SCXI modules)
- SCXI cable assembly
- Your computer
- NI-DAQ driver software for PC compatibles or Macintosh
- One of the following software packages:
 - LabVIEW for Macintosh
 - LabVIEW for Windows
 - LabWindows/CVI for Windows
 - ComponentWorks
 - VirtualBench

Identifying Your SCXI Components

The basic components of the SCXI system are terminal blocks, modules, chassis, cable assemblies, DAQ devices, and software, as shown in Figure 1-2. The following sections briefly describe the components of an SCXI system and help you to understand how they work together.

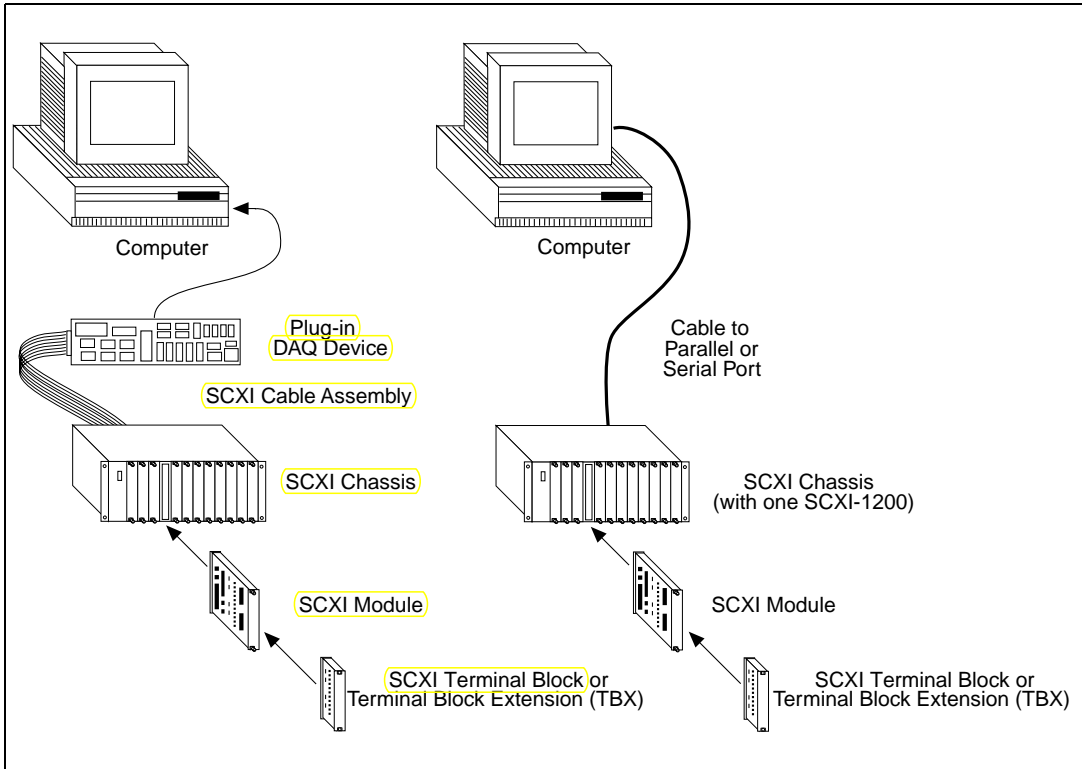

Figure 1-2. SCXI System Components

SCXI Chassis

The SCXI chassis houses the SCXI modules, supplying power and controlling the SCXIbus. National Instruments offers four SCXI chassis:

- SCXI-1000 4-slot chassis
- SCXI-1000DC 4-slot, DC-powered chassis
- SCXI-1001 12-slot chassis
- SCXI-2000 4-slot, RS-232/485 serial communication chassis

The rugged aluminum SCXI chassis contains an analog bus, a digital bus, and a chassis controller that regulates bus operation, as shown in Figure 1-3. The analog bus transfers analog signals from all resident analog input modules to the DAQ device using a connection from one of the modules to the DAQ device. The digital lines of the DAQ device communicate with the SCXI chassis controller and manipulate the digital bus, which controls chassis operation.

The SCXI-2000 chassis also includes a communication processor that you can use to connect the SCXI system directly to the RS-232 serial port of a computer, or to an RS-485 network for long-distance data acquisition.

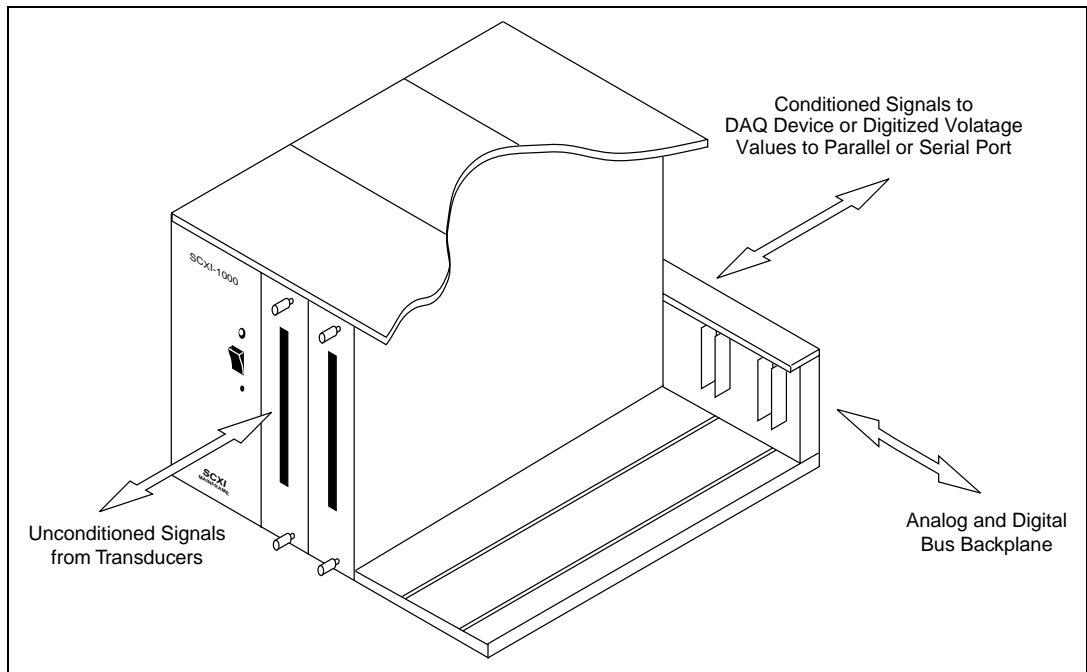

Figure 1-3. SCXI Chassis Signal Routing

SCXI Modules

National Instruments manufactures a variety of SCXI modules for use in SCXI chassis. Various analog input modules can multiplex, amplify, filter, and isolate voltage and current signals. Some modules have excitation potentials or currents and half-bridge completion networks for transducers such as strain gauges or resistive temperature devices (RTDs). Digital modules isolate digital signals through relays or optocouplers.

With the SCXI-1181 breadboard module, you can easily implement custom signal conditioning circuits.

The SCXI-2400 module is a serial communication module with the same RS-232 and RS-485 capabilities as the SCXI-2000 chassis. Use the SCXI-2400 in an RS-485 network for remote or long-distance data acquisition.

Table 1-1 lists the National Instruments SCXI modules and accessories. For further descriptions of National Instruments SCXI modules, refer to Chapter 3, *Configuring Your SCXI Hardware and Software*.

Table 1-1. SCXI Modules

Product	Classification	Description
SCXI-1100	Analog input	32-channel differential multiplexer/amplifier
SCXI-1102/B/C	Analog input	32-channel amplifier module for low voltages
SCXI-1104/C	Analog input	32-channel amplifier module for medium voltages
SCXI-1112	Analog input	8-channel amplifier module for thermocouples
SCXI-1120/D	Analog input	8-channel isolated amplifier
SCXI-1121	Analog input	4-channel isolated amplifier with excitation
SCXI-1122	Analog input	16-channel isolated multiplexer with excitation
SCXI-1124	Analog output	6-channel isolated D/A converter
SCXI-1125	Analog input	Jumperless SCXI-1120
SCXI-1126	Analog input	8-channel isolated frequency-to-voltage converter
SCXI-1140	Analog input	8-channel simultaneously-sampling differential amplifier
SCXI-1141	Analog input	8-channel programmable elliptic lowpass filter
SCXI-1142	Analog input	8-channel programmable Bessel lowpass filter
SCXI-1143	Analog input	8-channel programmable Butterworth lowpass filter
SCXI-1520	Analog input	8-channel deluxe bridge with excitation
SCXI-1530	Analog input	4-channel accelerometer module
SCXI-1531	Analog input	8-channel accelerometer module
SCXI-1540	Analog input	8-channel LVDT signal conditioner
SCXI-1160	Digital	16-channel electromechanical single-pole double-throw (SPDT) relay module
SCXI-1161	Digital	8-channel electromechanical SPDT relay module
SCXI-1162	Digital input	32-channel optically-isolated digital input module
SCXI-1162HV	Digital input	32-channel optically-isolated high-voltage digital input module

Table 1-1. SCXI Modules (Continued)

Product	Classification	Description
SCXI-1163	Digital output	32-channel optically-isolated digital output
SCXI-1163R	Digital output	32-channel optically-isolated solid-state relay
SCXI-1180	Accessory	Feedthrough panel
SCXI-1181	Accessory	Breadboard
SCXI-1200	Analog, digital, and timing I/O	Multifunction module with parallel port communication
SCXI-2400	Serial communication	RS-232/RS-485 serial communication interface

SCXI Terminal Blocks

SCXI terminal blocks attach directly to the front of an SCXI module and provide a quick, convenient method for connecting I/O signals to your system. There are two types of SCXI terminal blocks—direct-mount or TBX.

Direct-mount terminal blocks connect transducers to the screw terminals that are in a fully shielded terminal block enclosure. Strain-relief clamps hold the signal wires in place.

Terminal block extensions (TBXs) are DIN rail-mountable and attach to SCXI modules with shielded cables. These TBX terminal blocks are functionally equivalent to their direct-mount terminal block counterparts. Figure 1-4 shows the terminal block options and Table 1-2 lists the modules with which they work. Table 1-3 lists the TBX terminal blocks and the modules with which they work.

Several terminal blocks have a temperature sensor for cold-junction compensation with thermocouples. Terminal blocks can also perform additional signal conditioning function, including high-voltage attenuation, AC/DC coupling, bridge offset nulling, and shunt calibration.

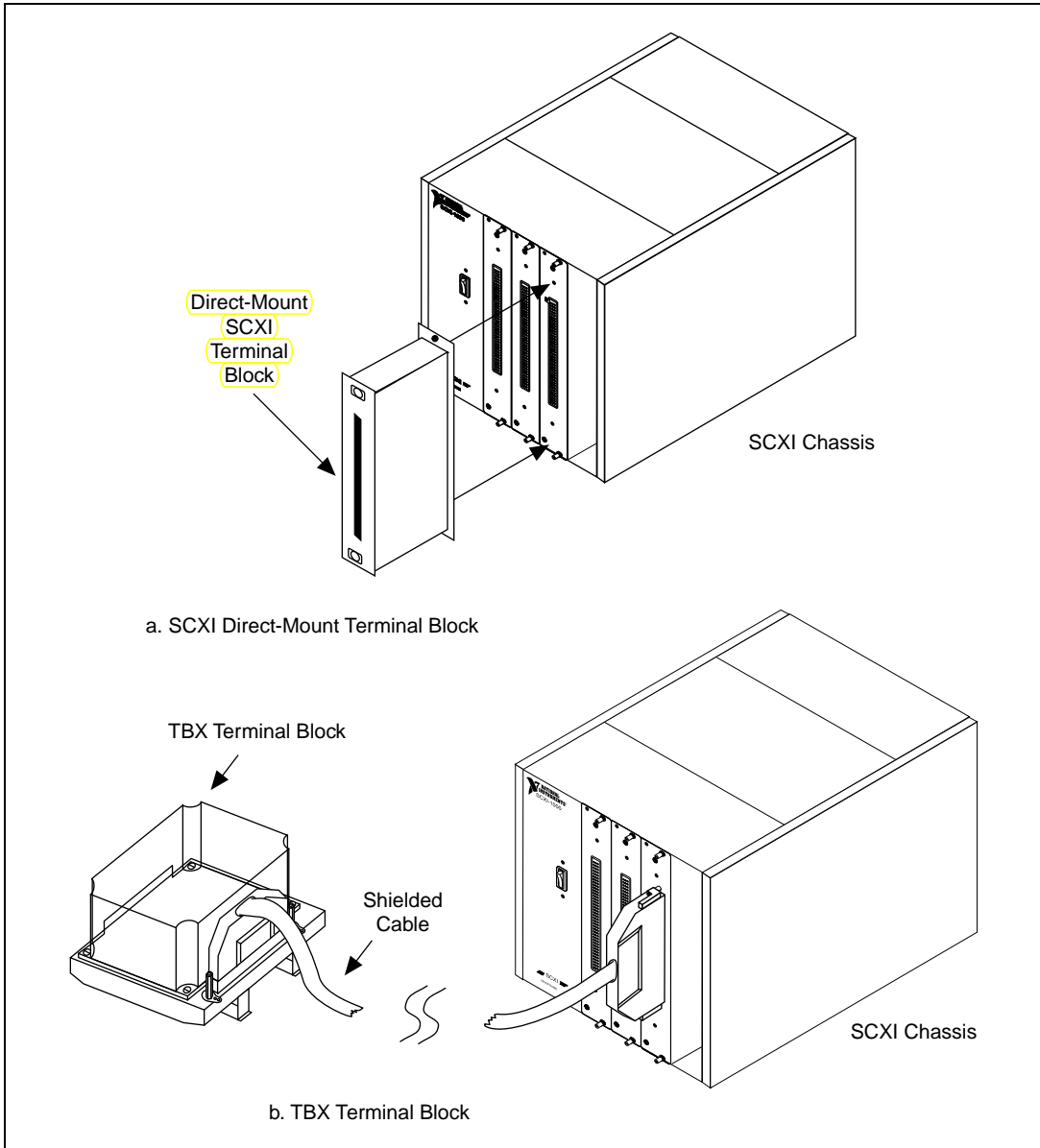

Figure 1-4. Terminal Block Options

Table 1-2. Direct-Mount Terminal Blocks

Module	Terminal/ Connector Block	Terminal Block or Connector and Shell	CJC Sensor	Other Features
SCXI-1100, SCXI-1102/B/C	SCXI-1300	Terminal block	Yes	—
	SCXI-1303	Terminal block	Yes ¹	Isothermal, signal referencing, and open thermocouple detection
	SCXI-1308	Terminal block	No	0–20 mA and 4–20 mA current input
	SCXI-1310	Connector and shell	No	Low-cost connector-and-shell assembly
SCXI-1104/C	SCXI-1300	Terminal block	Yes	—
SCXI-1112	N/A	No terminal block required	N/A	Connect thermocouples directly using mini-thermocouple connectors, built-in CJC sensor per channel
SCXI-1120/D, SCXI-1121, SCXI-1125	SCXI-1320	Terminal block	Yes	—
	SCXI-1321 (for SCXI-1121)	Terminal block	Yes	Offset-nulling and shunt calibration for strain gauges
	SCXI-1327	Terminal block	Yes ¹	100:1 attenuation of voltages to $250 V_{\text{rms}}^2$, switch configurable per channel
	SCXI-1328	Terminal block	Yes ¹	Isothermal design for thermocouples
	SCXI-1330	Connector and shell	No	Low-cost connector-and-shell assembly
	SCXI-1338	Terminal block	No	0–20 mA and 4–20 mA current input
SCXI-1122	SCXI-1322	Terminal block	Yes ¹	—
SCXI-1124	SCXI-1325	Terminal block	No	—
SCXI-1126	SCXI-1305	Terminal block	No	AC/DC coupling, signal referencing, switch-configurable per channel, BNC connectors
	SCXI-1320	Terminal block	Yes	—
	SCXI-1327	Terminal block	Yes ¹	100:1 attenuation of voltages to $250 V_{\text{rms}}^2$, switch configurable per channel

Table 1-2. Direct-Mount Terminal Blocks (Continued)

Module	Terminal/Connector Block	Terminal Block or Connector and Shell	CJC Sensor	Other Features
SCXI-1140	SCXI-1301	Terminal block	No	—
	SCXI-1304	Terminal block	No	AC/DC coupling, switch configurable per channel
	SCXI-1305	Terminal block	No	AC/DC coupling signal referencing, switch-configurable per channel, BNC connectors
	SCXI-1310	Connector and shell	No	Low-cost connector and shell assembly
SCXI-1141, SCXI-1142, SCXI-1143	SCXI-1304	Terminal block	No	AC/DC coupling, switch-configurable per channel
	SCXI-1305	Terminal block	No	AC/DC coupling, switch-configurable per channel, BNC connectors
	SCXI-1310	Connector and shell	No	Low-cost connector-and-shell assembly
SCXI-1160	SCXI-1324	Terminal block	No	—
SCXI-1161	—	No terminal block—screw terminals in module		
SCXI-1162/1162HV, SCXI-1163/1163R	SCXI-1326	Terminal block	No	—
SCXI-1180	SCXI-1302	Terminal block	No	—
SCXI-1181, SCXI-1181K	SCXI-1300	Terminal block	Yes	—
	SCXI-1301	Terminal block	No	—
	SCXI-1310	Connector and shell	No	—
	SCXI-1330	Connector and shell	No	—
SCXI-1200	SCXI-1302	Terminal block	No	—
SCXI-1520	SCXI-1314	Terminal Block	No	Socketed quarter-bridge completion resistor per channel, two socketed shunt-calibration resistors per channel
	SCXI-1310	Connector and shell	No	—
SCXI-1530 SCXI-1531	N/A	No terminal block required	No	Connect signals directly using BNC connectors

Table 1-2. Direct-Mount Terminal Blocks (Continued)

Module	Terminal/ Connector Block	Terminal Block or Connector and Shell	CJC Sensor	Other Features
SCXI-1540	SCXI-1315	Terminal block	No	—
	SCXI-1310	Connector and shell	No	—
SCXI-2400	N/A	N/A	N/A	Serial communication module
¹ The SCXI-1303, SCXI-1322, SCXI-1327, and SCXI-1328 use an onboard thermistor for sensing cold-junction temperature. Other terminal blocks use an IC temperature sensor. ² 300V _{rms} when used with the SCXI-1125				

Table 1-3. TBX Terminal Blocks for SCXI

Term. Bks	SCXI Modules										CJC Sensor	Required Cables
	1100/ 1102/ B/C	1120/D 1121 1122	1124	1140/ 1141/ 1142/ 1143	1160	1161	1162/ 1162HV/ 1163/ 1163R	1180	1181/ 1181K	1200		
TBX-1303	√	—	—	—	—	—	—	—	—	—	√ ¹	SH96-96 or R96-96
TBX-1328	—	√	—	—	—	—	—	—	—	—	√ ¹	SH32-32-A
TBX-1325	—	—	√	—	—	—	—	—	—	—	—	SH48-48-A
TBX-1326	—	—	—	—	—	—	—	—	—	—	—	SH48-48-B
TBX-24F	—	—	√	√	√	√	—	—	—	—	—	User-supplied wiring
CB-50	—	—	—	—	—	—	—	—	—	√	—	NB1

¹ The TBX-1303 and TBX-1328 use an onboard thermistor for sensing cold-junction temperature.

Connector-and-Shell Assemblies

Connector-and-shell assemblies are low-cost alternatives to SCXI terminal blocks and are less rugged, plastic assemblies that connect signals using solder pins.

DAQ Plug-In Devices and PC Cards

You can connect the conditioned analog signals from an SCXI system directly to a plug-in DAQ device or DAQCard. Using SCXI multiplexing capability, a single plug-in DAQ device or DAQCard can measure up to 3,072 conditioned analog signals.

You can use any of the following DAQ devices to control an SCXI system:

- Multifunction I/O (MIO) and AI devices can control single-chassis or multichassis SCXI systems consisting of any combination of analog and digital SCXI modules. Use MIO and AI devices for systems that require high-speed, hardware-controlled scanning.
- You can use all E Series AT, PCMCIA, PCI, and PXI bus devices except the 6110 and 6111 devices.

Lab/1200 Series devices can control single-chassis SCXI systems consisting of any combination of analog and digital SCXI modules.

DIO devices can control single-chassis or multichassis SCXI systems consisting of digital SCXI modules.

DAQ Modules

As an alternative to a plug-in DAQ device or DAQCard, you can use an SCXI DAQ module, such as the SCXI-1200. The SCXI-1200, which is functionally similar to the PCI-1200 and DAQCard-1200, can control single-chassis systems with any combination of analog and digital modules. The SCXI-1200 connects to the computer parallel port, or to the SCXI-2000 chassis or SCXI-2400 module, which in turn communicates with the computer using a serial port.

SCXI Cable Assemblies

If you are using a plug-in DAQ device or DAQCard, connect it to the SCXI chassis using one of the SCXI cable assemblies listed in Table 1-4.

Table 1-4. SCXI Cable Assemblies

Cable Assembly	Device Connection
SCXI-1343	Screw-terminal adapter for custom configurations
SCXI-1348	DIO-32F
SCXI-1349	MIO E Series devices with 68-pin connector
SCXI-1353	MIO E Series devices with 100-pin connector
SCXI-1354	DAQCard-1200
SCXI-1355	AT-DIO-32HS, PCI-DIO-32HS
NB5 ribbon cable with optional SCXI-1351	PC-DIO-96/PnP
R1005050 with optional SCXI-1351	PCI-DIO-96

Some cable assemblies have extra male breakout connectors with which you can access unused DAQ device signals through the SCXI-1180 feedthrough panel or the SCXI-1181 breadboard module. The SCXI-1200 comes with a 1 m parallel port cable.

SCXI Multichassis System with Plug-In DAQ Device

For a multichassis SCXI system, that is cabled using an SCXI-1346 or SCXI-1350, chassis are daisy-chained using multichassis adapters with shielded or unshielded cables to a single plug-in DAQ device. You can control up to eight SCXI-1000, SCXI-1000DC, or SCXI-1001 chassis with a single AI, MIO, or DIO-24 device. Figure 1-5 shows a multichassis configuration using the SCXI-1346 multichassis adapter.

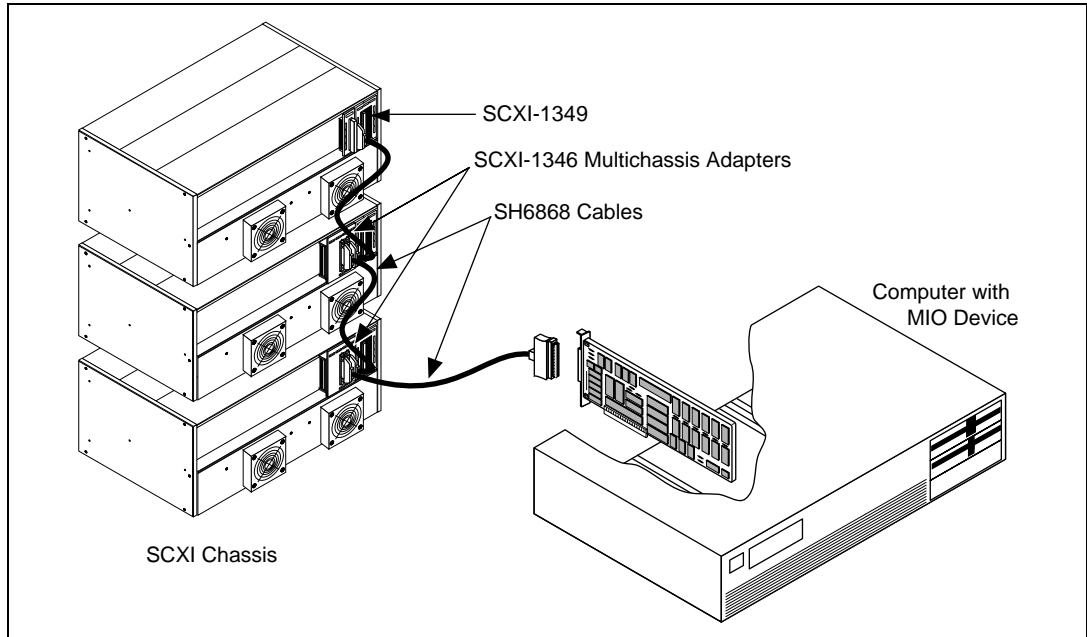

Figure 1-5. Multichassis SCXI System with Shielded Cabling

When using shielded cabling for a multichassis configuration, the maximum allowable cable length from the DAQ device to the last chassis is 10 m.

Optional Software

The final component of an SCXI system is software. You can program your SCXI system using NI-DAQ driver software, LabWindows/CVI, LabVIEW for Windows, LabVIEW for Macintosh, or ComponentWorks.

NI-DAQ driver software ships with your National Instruments DAQ device, SCXI-1200, SCXI-2000, or SCXI-2400. NI-DAQ has a library of functions that you can call from your application development environment (ADE).

Alternatively, you can use LabVIEW for Windows, LabVIEW for Macintosh, LabWindows/CVI for Windows, or ComponentWorks. LabVIEW and LabWindows/CVI are innovative program development software packages for data acquisition and control applications. LabVIEW uses graphical programming, whereas LabWindows/CVI enhances ANSI C. Both packages include extensive libraries for data acquisition, instrument control, data analysis, and graphical data presentation.

ComponentWorks is a collection of object linking and embedding (OLE) controls and dynamic link libraries (DLLs) for acquiring, analyzing, and presenting data within Visual Basic.

Whether you are using conventional programming languages, LabVIEW, LabWindows/CVI, or ComponentWorks, your application uses the NI-DAQ driver software, as illustrated in Figure 1-6.

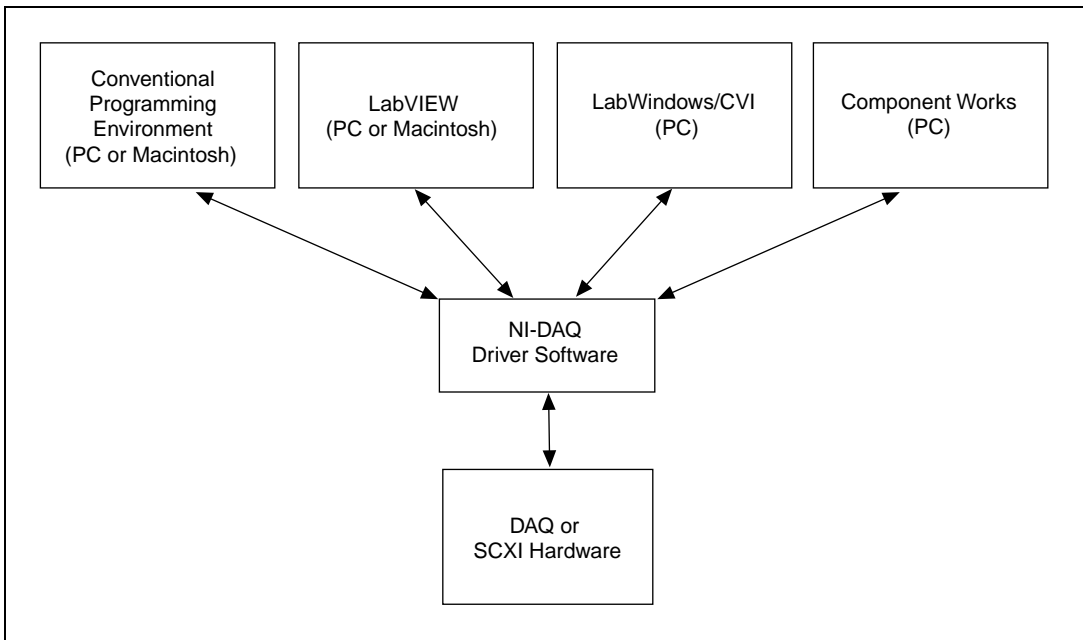

Figure 1-6. The Relationship Between the Programming Environment, NI-DAQ, and the DAQ Hardware

Overview of SCXI Operation

This section describes on the SCXI analog input modules, and analog and digital output modules used with DAQ devices.

Analog Input Modules

Table 1-1 lists the analog input modules. Analog SCXI modules can operate in parallel or multiplexed mode. In parallel mode, the modules perform no signal multiplexing and simply pass the conditioned signals directly to corresponding channels on the DAQ device. Therefore, each module is directly connected to its own DAQ device.

You will probably operate your analog SCXI modules in multiplexed mode. You can multiplex thousands of conditioned analog input signals into a single DAQ device. In this mode, connect the plug-in DAQ device to only one SCXI module in a chassis. Digital lines on the DAQ device control the modules and chassis. The DAQ device uses three or four digital output lines and the EXTSTROBE line to program the SCXI system. In addition, a digital input line is used for reading information back from the SCXI modules.

When using SCXI analog input modules, you can measure analog input signals by doing single-channel readings or hardware-timed, multiple-channel scanning.

During single-channel readings, the DAQ device serially writes a digital pattern to SCXI Slot 0, located in the chassis, indicating which SCXI module to address. The DAQ device then writes a digital pattern to the module indicating which input channel is to be read. This configures the module to route the desired signal to the analog bus of the SCXI chassis. Ultimately, the signal is routed to analog input channel 0 of the DAQ device. The DAQ device then reads channel 0, as shown in Figure 1-7. NI-DAQ automatically performs this low-level digital communication and signal routing when you call the single-channel analog input functions.

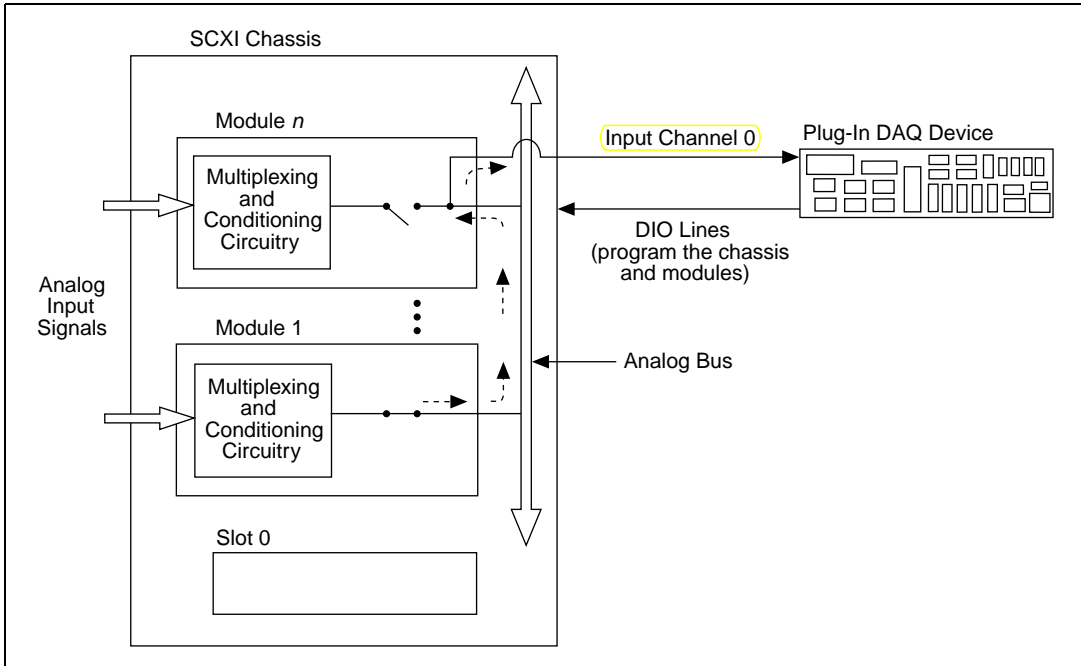

Figure 1-7. SCXI Signal Routing

With **multichannel scanning**, the DAQ device programs SCXI Slot 0 with a list of modules and the number of channels to scan from each module. Each module in the list is programmed with the channel on which to start the scan. The DAQ device or module then begins the multichannel scan. The SCANCLK signal from the AI or MIO device synchronizes the SCXI multiplexing with the internal clock that triggers the A/D conversions on the DAQ device. SCXI Slot 0 enables and disables the modules according to the preprogrammed list. In this way, the system multiplexes channels from several modules to an analog input channel of the DAQ device at very high rates. NI-DAQ contains high-level functions you can use for multichannel scanning operations.

Analog and Digital Output Modules

Digital SCXI modules include the SCXI-116X modules. Digital SCXI modules can operate in either serial mode or parallel mode. In serial mode, the SCXI system uses a maximum of four digital output lines and one digital input line of the DAQ device to control and monitor multiple digital modules. The plug-in device serially writes digital patterns to set the state of the digital output lines or relays, or serially reads patterns from the modules to determine the state of the digital input lines. In parallel mode, each SCXI digital I/O line corresponds to a digital I/O line of the DAQ device.

The SCXI-1162, SCXI-1162HV, SCXI-1163, and SCXI-1163R can operate in parallel mode. The SCXI-1160 and SCXI-1161 operate only in serial mode. Refer to Chapter 3, *Configuring Your SCXI Hardware and Software*, for more information.

The SCXI-1124 is a 6-channel isolated analog output module. As with the digital I/O modules, the SCXI-1124 is programmed serially by the DAQ device using a maximum of four digital output lines and one digital input line.

Installing SCXI Modules and Connecting the SCXI System to the DAQ Device

This chapter describes how to install your SCXI hardware and how to connect your SCXI system to your computer.

Installing Your Software

All SCXI system configurations require NI-DAQ software. Whether you are using LabVIEW, LabWindows/CVI, ComponentWorks, or a third-party compiler, you must install the NI-DAQ driver software and Measurement & Automation Explorer to use your DAQ/SCXI system.

1. You receive NI-DAQ software with your DAQ device, SCXI-1200, SCXI-2400, or SCXI-2000.
 - If you are using LabWindows/CVI, install LabWindows/CVI first. Next, install NI-DAQ for PC compatibles and run the setup option, then select the LabWindows/CVI option to install LabWindows/CVI DAQ support.
 - LabVIEW includes all the NI-DAQ files you need to control the SCXI system. However, NI-DAQ for PC compatibles also has a LabVIEW update option that installs newer driver files in your system when the installation utility detects older files on your hard disk.
2. If you already have installed Measurement & Automation Explorer and the driver software and you received a newer NI-DAQ version, install the newer version now.

Installing Your DAQ Device

If you are using SCXI with a plug-in DAQ device or DAQCard, install your DAQ hardware into your computer now and configure your DAQ device with Measurement & Automation Explorer. Refer to your DAQ device user manual for installation instructions.

Installing Your SCXI Modules



Caution Before installing an SCXI module or removing a module from the chassis, turn off power to the chassis.

Follow this procedure to install your SCXI modules:

1. To insert a module into the chassis, **line up** the module with the chassis device guides. Slide the module back until it connects smoothly to the SCXI chassis backplane. **Do not force the module.** If the module does not connect smoothly, check that it is aligned correctly.
2. Tighten the thumbscrews finger-tight. **Do not over-tighten.**
3. Repeat steps 1 and 2 until you have installed all of your modules.

Connecting the SCXI System to the DAQ Device or Computer

This section explains how to connect your SCXI to a DAQ device or a computer using a parallel port, **plug-in DAQ device or DAQCard,** and an RS-232 or RS-485 Serial port.

Using the Parallel Port

Connect the parallel port cable to the computer parallel port. Connect the other end of the cable to the SCXI-1200 and tighten the mounting screws on the connectors to establish a firm connection.

Using a Plug-in DAQ Device or DAQCard

If you are using an SCXI module with a DAQ device or DAQCard, connect the SCXI chassis to your DAQ device with an **SCXI-134X** or SCXI-135X cable assembly. In certain instances, you can also use a 50-pin NB1 or 100-pin NB5 or NB6 ribbon cable in conjunction with an SCXI-1351 cable assembly.

To connect the SCXI chassis to your DAQ device, you must connect the appropriate SCXI cable assembly to the DAQ device and then connect the other end to the rear connector of a single SCXI module. Use the following procedure:

1. Determine to which SCXI module you will connect the SCXI cable assembly. If all modules are configured for multiplexed or serial mode, you must cable *only one module to a DAQ device.* Use the following rules to determine which is the proper SCXI module to connect to the cable:
 - For systems containing *at least one analog SCXI module*:
 - a. If you are using one or more SCXI-1140 modules, connect the cable assembly to any one of the SCXI-1140 modules. The SCXI-1140 requires a counter signal from the DAQ device to control the track-and-hold circuitry. Cable only one SCXI-1140 to the DAQ device because other SCXI-1140 modules in the chassis can access the track-and-hold counter signal through the SCXIbus in the chassis backplane.
 - b. If you are not using an SCXI-1140 and are using one or more SCXI-110X module, connect the cable assembly to any one of the SCXI-110X module. The SCXI-110X module drives only two of the DAQ device analog input lines, leaving the other lines available.
 - c. If you are not using any SCXI-1140 or SCXI-110X modules but are using other analog modules, connect the cable assembly to any one of the analog modules.
 - For systems containing *only digital modules* (no analog modules), connect the cable assembly to any one of the digital modules.
 - For systems containing *both analog and digital modules*, follow steps a through c for connecting an analog module. Enable the MISO and SERDATOUT lines of the module you connect to the DAQ device. For more information see Chapter 3, *Configuring Your SCXI Hardware and Software*.
 - If the system contains any digital modules configured for parallel mode, connect each of these digital modules to a separate DIO device. If the system contains any analog modules configured for parallel mode, connect each of these modules to a separate analog DAQ device.

2. Connect the connector at the bracket end of the SCXI cable assembly to the rear signal connector of the module. Figure 2-1 shows the cable assembly attached to the SCXI module and chassis.

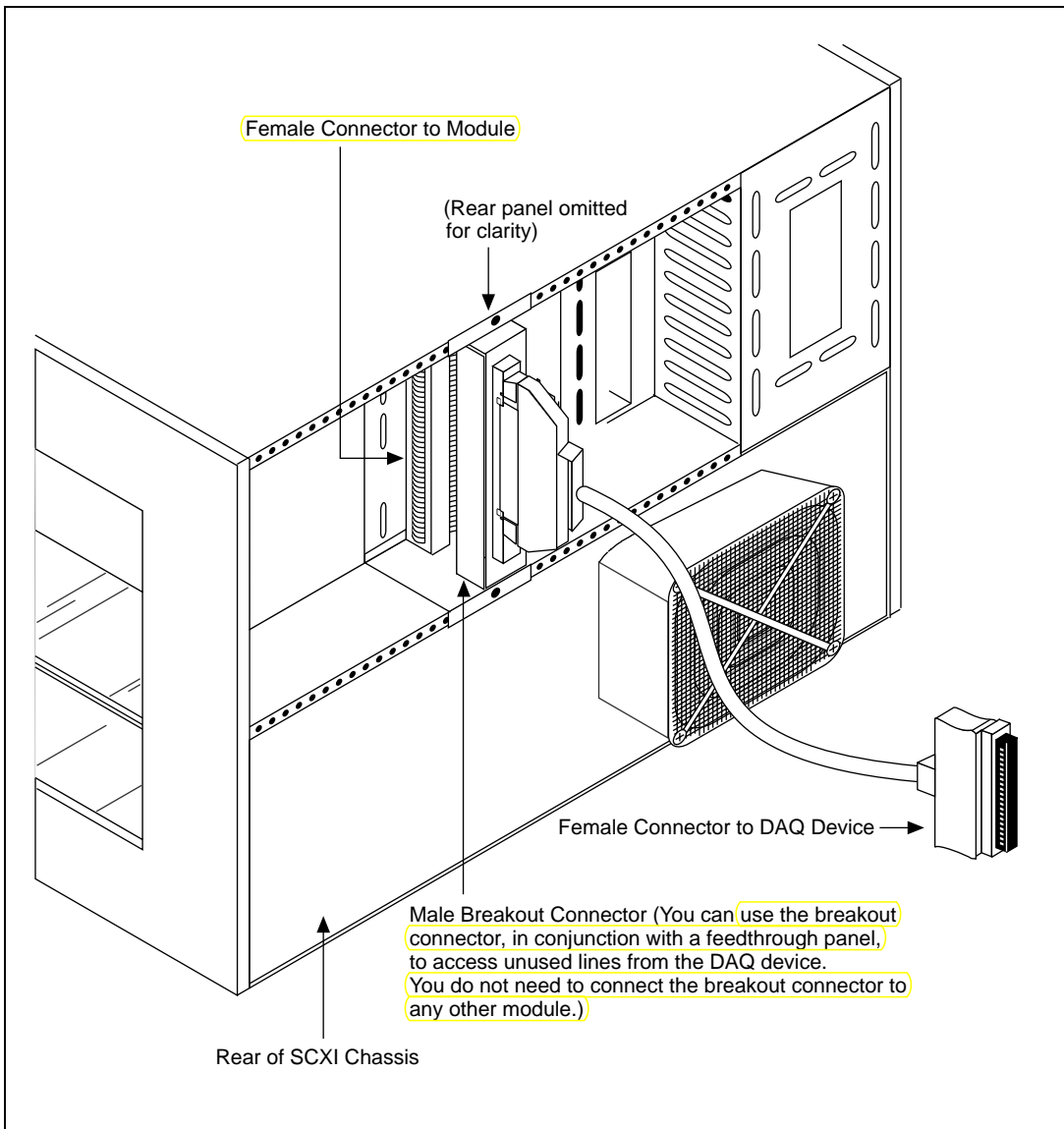

Figure 2-1. Attaching the SCXI Cable Assembly to the SCXI Module and Chassis

The DAQ device communicates with the SCXIBus through the connector at the bracket end of the cable assembly. Therefore, *you do not need to connect the remaining modules to the SCXI cable assembly.* Notice that the extra male breakout connector of the SCXI cable assembly is usually not connected to other modules. *You can use this male breakout connector to connect unconditioned signals from the DAQ device to an SCXI-1180 feedthrough panel, SCXI-1181 breadboard module, or the SCXI-1351 one-slot cable extender.*

In some cases, you can use an NB1 cable instead of the SCXI-1340 cable assembly. The NB1 cable and the SCXI-1340 are functionally identical; however, the SCXI-1340 ensures a more secure attachment than the NB1 cable, eliminating the possibility of inadvertently loosening the cable. The SCXI-1340 also has an extra male breakout connector that provides access to unconditioned signals using an SCXI-1180 feedthrough panel or SCXI-1181 breadboard module.

Cable assemblies also have an integral rear panel that you can fasten to the SCXI chassis with two screws. Using a cable assembly, you can remove a module from or insert a module into the chassis without disconnecting the cable.

3. If you are using an SCXI-1180 feedthrough panel to access unused lines of the DAQ device, install the feedthrough panel in the slot directly to the right of the module cabled to the DAQ device. *Attach the SCXI-1180 feedthrough panel cable to the 50-pin male breakout connector of the SCXI cable assembly connected to the adjacent module.*
4. If you are using an SCXI-1181 breadboard module, install the breadboard module in the slot directly to the right of the module that is connected to the DAQ device. Attach an SCXI-1351 one-slot cable extender to the 50-pin male breakout connector of the SCXI cable assembly connected to the adjacent module. Attach the other end of the SCXI-1351 to the rear signal connector of the SCXI-1181 breadboard module.

If you want to use more than 12 modules with a single DAQ device, you must use more than one SCXI chassis. In this case, you must use multichassis adapters.

Using an RS-232 or RS-485 Serial Port

You can use the RS-232 port on your computer to control one chassis up to 100 ft from your computer. If your chassis is farther away or you are using multiple chassis, you must use RS-485.

If you are using an SCXI-2400 module, insert the SCXI-2400 into the far left slot of your SCXI-100X chassis and insert the SCXI-1200 module immediately next to it. Attach the connector adapter that is shipped with the SCXI-2400 module to the rear of the SCXI-2400. Connect the SCXI-1200 to this connector adapter using a 7 in. IEEE 1284 parallel port cable.

If you are using an SCXI-2000 chassis, insert the SCXI-1200 into the far left slot of your SCXI chassis. Next, connect the 7 in. IEEE 1284 parallel port cable to the back of the SCXI-1200 and the SCXI-2000 chassis.



Note If your SCXI chassis includes only analog output and digital I/O modules, you do not need the SCXI-1200 module. The SCXI-2000 and SCXI-2400 can communicate directly with analog output and digital I/O modules.

Next, connect the SCXI-2000 or SCXI-2400 to an RS-232 or RS-485 port of your computer.

- **RS-232**—You can connect one SCXI chassis directly to the standard COM serial port of your computer. If your computer has a 9-pin communication port, use the 2 m null modem cable included with the SCXI-2000/2400 to connect the 9-pin RS-232 connector on the front panel of the SCXI-2000/2400 to the serial port of your computer.
- **RS-485**—Alternatively, you can connect the RS-485 connectors on the back of the SCXI-2000 chassis or SCXI-2400 module to an RS-485 network. For example, you can wire the RS-485 connector directly to a port of the plug-in AT-485 adapter device. The RS-485 connection is a four-wire connection. See your SCXI chassis user manual or *SCXI-2400 User Manual* for more information on configuring an RS-485 network.

Configuring Your SCXI Hardware and Software

This chapter explains how to configure your SCXI hardware and National Instruments software.

Module Configuration

You may need to configure your SCXI modules before using them in your application. Some SCXI modules have a number of user-configurable jumpers that you can access by removing a single screw on the back of the module, as shown in Figure 3-1.

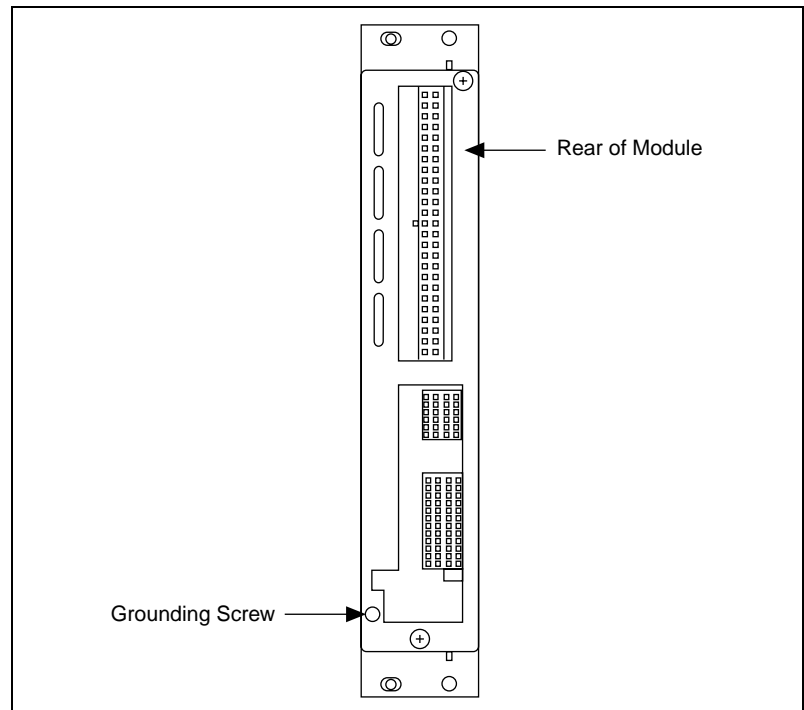

Figure 3-1. Removing the SCXI Module Grounding Screw

Use this procedure to access the user-configurable jumpers.

1. Remove the grounding screw shown in Figure 3-1.
2. Remove the cover by inserting a flathead screwdriver in the slot at the bottom of the module and gently pushing the screwdriver down until the cover pops off, as shown in Figure 3-2.

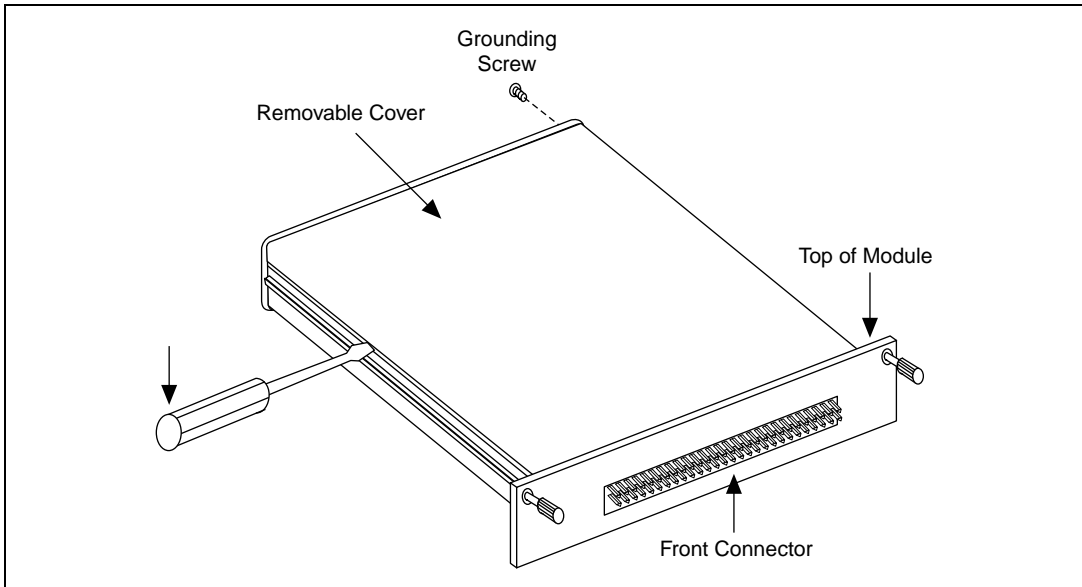

Figure 3-2. Removing the SCXI Module Cover

To replace the cover, follow these steps:

1. Align the cover with the slot at the top of the module and snap the bottom of the cover into place.
2. Replace the grounding screw, taking care not to over-tighten it.

Analog Modules

The following sections describe each analog SCXI module and contain step-by-step instructions for configuring the jumpers on each module. Follow the steps in the procedure for your module, check the position of each jumper, and read the jumper position description. Change the appropriate jumpers to configure the module for your application.

Each analog module includes jumpers that configure the output referencing mode of the module. Configure these jumpers according to the analog input mode of the DAQ device. The recommended analog input mode of your DAQ device is as follows:

- E Series AI and MIO devices default to differential (DIFF) mode. National Instruments recommends that you leave your AI or MIO device configured for DIFF inputs.
- The Lab/1200 devices default to referenced single-ended (RSE) mode. Change its configuration to non-referenced single-ended (NRSE) mode for optimal noise elimination. Because of the cabling, you cannot use the Lab and 1200 devices in DIFF mode with SCXI.

Some analog SCXI modules include jumpers to configure module parameters such as filter cut off frequency, gain, analog input referencing, and output referencing. You must select the analog input referencing of a module according to the type of signal you are measuring. This section begins with a description of the main types of signals.

Ground-Referenced and Floating Signal Sources

Signal sources are either ground-referenced or floating.

A ground-referenced source is connected to the building ground and thus shares a common ground with the DAQ device, assuming that your computer is connected to the building power supply as well. Examples of ground-referenced signals are the non-isolated outputs of any devices that plug into the building power supply, such as signal generators and power supplies. Isolated outputs are not ground-referenced sources; you should treat them as floating sources.

A floating source has an isolated ground-reference point that you cannot assume to be at the same potential as any other ground reference. Examples of this type of source include transformers, insulated thermocouples, optical isolators, isolation amplifiers, and battery-powered devices.

In general, you should reference an input signal to ground at only one point. Therefore, do not reference the input of a differential amplifier module to ground if the signal source is already ground-referenced. If you are measuring a floating source, on the other hand, reference the input signal to ground.

SCXI-1100 Module

This module is a 32-channel differential-input multiplexer with an onboard programmable-gain instrumentation amplifier (PGIA). The SCXI-1100 has 32 differential voltage or current input channels, an analog input range of ± 10 V, jumper-selectable lowpass filters of 4 Hz and 10 kHz, and software-selectable module gains of 1, 2, 5, 10, 20, 50, 100, 200, 500, 1,000, and 2,000. The SCXI-1100 works only in multiplexed mode and drives two analog input channels on the DAQ device—channel 0 and channel 1.

The SCXI-1100 is factory-configured for use with an MIO or AI device in DIFF mode, using ground-referenced signals, with no filtering. If this configuration is suitable, do not reposition any jumpers. However, you must adjust the configuration if any of the following conditions is true:

- You are cabling this SCXI-1100 directly to a DAQ device and you are using a Lab or 1200 device, or you are using an AI or MIO device in SE mode.
- Your input signals are floating or non-referenced and you want to ground reference the signals through a 100 k Ω resistor installed in the module; however, it is best to ground-reference the signals at the source or at the terminal block.
- You need hardware filtering and can accept slower scan rates.
- You are measuring current signals.

Read the rest of this section on the SCXI-1100 module if any of the previous conditions applies to you.

The SCXI-1100 module has five user-configurable jumpers for configuring input signal referencing, filtering, and PGIA output referencing. Leave all other jumpers in their factory-default positions.

Use the following procedure to configure your SCXI-1100 module:

1. Configure the input signal referencing mode.



For ground-referenced sources, leave jumper W1 in the factory-default position. This is the preferred position.



Caution If you plan to use any floating thermocouples or other floating-source transducers, National Instruments recommends that you leave jumper W1 in the factory-default setting and either ground the negative lead of each transducer to the chassis ground on your terminal block, or reference the transducer to ground at the source. In either case, the transducer must not have a high common-mode voltage. Ground your signal at

only one location along the entire signal path to prevent saturation of the amplifier and reduce common-mode noise.

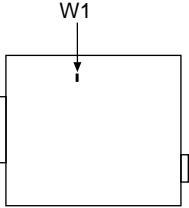
Table 3-1. SCXI-1100 Input Signal Referencing Jumper Configurations



Jumper	Description	Configuration
	<p>1-2 Position—Ground-referenced source position (factory-default position).</p> <p>2-3 Position—Floating (nonreferenced) source position (connects an internal 100 kΩ resistor from CH- to ground). Read the text in this section for the implications of using this position.</p>	

If all of the sources are floating, you can configure jumper W1 to connect a 100 k Ω resistor to the negative input of the amplifier to prevent saturation. This reduces the input impedance, however, and usually increases settling time and common-mode noise. Also, if W1 is connected to the 100 k Ω resistor and any of the sources are ground-referenced or have high leakage to ground, a ground loop can result, causing DC offsets or noise.

2. Configure the filtering.

The SCXI-1100 has two lowpass, one-pole resistance-capacitor (RC) filters, with bandwidths of 10 kHz and 4 Hz, positioned after the amplifier. You select filtering by setting a single jumper to one of three positions—W2, W3, or W4. Table 3-2 shows the SCXI-1100 filtering jumper configuration.

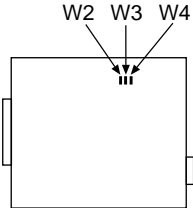
Table 3-2. SCXI-1100 Filtering Jumper Configuration

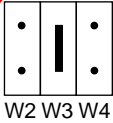
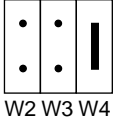
Jumper	Description	Configuration
	<p>W2—Full bandwidth; no filtering (factory-default position).</p>	
	<p>W3—10 kHz lowpass filter; maximum aggregate sampling rate is 6.7 kS/s.</p>	
	<p>W4—4 Hz lowpass filter; maximum aggregate sampling rate is 2.9 S/s.</p>	

Position W2, the factory-default position, disables filtering. Position W3 selects the 10 kHz lowpass filter, which filters out signal components with frequencies above 10 kHz. Position W4 selects the 4 Hz lowpass filter, which filters out signal components with frequencies greater than 4 Hz, such as 60 Hz noise. For more information, refer to the *Noise and Filtering* section in Chapter 4, [Connecting and Using Accessories and Transducers](#).



Caution If you enable filtering, you cannot scan SCXI-1100 channels at high rates. Because the filter is applied after the signal is multiplexed, the sample rate or channel rate must be low enough for the filter to settle to the required accuracy. Table 3-2 shows the maximum recommended aggregate sampling rates for settling under worst-case conditions.

3. Configure the PGIA output referencing mode.

You use jumper W10 to select the output referencing mode of the SCXI-1100 PGIA. The correct output referencing mode depends on the input mode of the DAQ device. Table 3-3 shows three configurations for jumper W10.

Table 3-3. SCXI-1100 PGIA Output Referencing Jumper Configuration

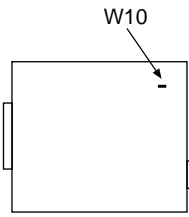
Jumper	Description	Configuration												
	A-R0R1—Parking position. Use this position for MIO or AI DAQ devices in DIFF input mode (factory-default position).	<table border="1"> <thead> <tr> <th></th> <th>A</th> <th>B</th> </tr> </thead> <tbody> <tr> <td>R0</td> <td>█</td> <td>•</td> </tr> <tr> <td>R1</td> <td>█</td> <td>•</td> </tr> <tr> <td>R2</td> <td>•</td> <td>•</td> </tr> </tbody> </table>		A	B	R0	█	•	R1	█	•	R2	•	•
		A	B											
	R0	█	•											
R1	█	•												
R2	•	•												
AB-R0—Connects the PGIA reference to data acquisition analog ground, pins 1 and 2, of the rear signal connector. Use this position for DAQ devices with SE inputs, such as the Lab and 1200 devices, or MIO and AI devices in RSE mode.	<table border="1"> <thead> <tr> <th></th> <th>A</th> <th>B</th> </tr> </thead> <tbody> <tr> <td>R0</td> <td>█</td> <td>█</td> </tr> <tr> <td>R1</td> <td>•</td> <td>•</td> </tr> <tr> <td>R2</td> <td>•</td> <td>•</td> </tr> </tbody> </table>		A	B	R0	█	█	R1	•	•	R2	•	•	
	A	B												
R0	█	█												
R1	•	•												
R2	•	•												
AB-R2—Select this position for AI or MIO devices in NRSE mode.	<table border="1"> <thead> <tr> <th></th> <th>A</th> <th>B</th> </tr> </thead> <tbody> <tr> <td>R0</td> <td>•</td> <td>•</td> </tr> <tr> <td>R1</td> <td>•</td> <td>•</td> </tr> <tr> <td>R2</td> <td>█</td> <td>█</td> </tr> </tbody> </table>		A	B	R0	•	•	R1	•	•	R2	█	█	
	A	B												
R0	•	•												
R1	•	•												
R2	█	█												

- Add current-loop receivers, if necessary. Process-current resistor packs are available from National Instruments. Refer to *Input Filtering and Current-Loop Receivers* in the *SCXI-1100 User Manual* for detailed information about filter pads and current loop receivers.

SCXI-1102/B/C Module

The SCXI-1102/B/C is a 32-channel amplifier module designed for measuring thermocouples and other low-bandwidth signals. Each of the 32 channels includes input protection circuitry to 42 VAC_{peak} and a software-selectable gain of 1 or 100. The SCXI-1102, SCXI-1102/B, and SCXI-1102/C have lowpass filters with cutoff frequencies of 2 Hz, 200 Hz, and 10 kHz respectively. The SCXI-1102 works only in multiplexed mode and drives a single analog input channel on the DAQ device (channel 0). The SCXI-1102/B/C is software configurable and contains no jumpers.

SCXI-1104/C Module

- ◆ SCXI-1104
This module is for signal conditioning of low voltage and medium voltage signals. The SCXI-1104 has 32 differential analog input channels. On each channel, the SCXI-1104 has a three-pole lowpass filter with a 2 Hz cutoff frequency to reject 60 Hz noise. Each channel also has a divide by 10 attenuator stage before the amplifier. You can multiplex the SCXI-1104 inputs to a single output, which drives a single DAQ device channel.
- ◆ SCXI-1104C
This module is for signal conditioning of low voltage and medium voltage signals. The SCXI-1104C has 32 differential analog input channels. On each channel, the SCXI-1104C has a three-pole lowpass filter with a 10 kHz cutoff frequency. Each channel also has a divide by 10 attenuator stage before the amplifier. You can multiplex the SCXI-1104C inputs to a single output, which drives a single DAQ device channel.

SCXI-1112 Module

The SCXI-1112 module is an 8-channel module designed for measuring temperature using thermocouples. Each of the eight channels includes input protection circuitry to 42 V, a lowpass 2 Hz noise filter, and a fixed gain of 100. The SCXI-1112 works only in multiplexed mode. Use Measurement & Automation Explorer to configure the SCXI-1112. The SCXI-1112 is software configurable and contains no jumpers.

SCXI-1120/D Module

The SCXI-1120/D module is an 8-channel isolation amplifier. Features of the SCXI-1120/D include eight isolated input channels, 250 V_{rms} common-mode voltage range, jumper-selectable lowpass filtering, and individually configurable jumper-selectable channel gains of 1, 2, 5, 10, 20, 50, 100, 200, 500, 1,000, and 2,000.

The SCXI-1120/D is factory configured for use with an MIO or AI device in DIFF mode; each module channel is configured for a gain of 1,000 (input range of ± 5 mV), and 4 Hz filtering (4.5 kHz for the SCXI-1120/D). If this configuration is suitable for your application, do not reposition any of the

jumpers. However, you must adjust the jumper configuration if any of the following conditions is true:

- You are cabling this SCXI-1120/D directly to a DAQ device and you are using a Lab or 1200 device, or you are using an AI or MIO device in SE mode.
- You need gain or bandwidth different from the default value on any channel.
- You are using digital modules in the same chassis, and are cabling the SCXI-1120/D to a DAQ device.

Read the rest of this section on the SCXI-1120/D module if any of the previous conditions applies to you.

The SCXI-1120/D has 42 user-configurable jumpers, many of which perform the same function but configure different channels. You can set the jumpers to configure gain, filtering, temperature sensor signal routing, and signal output referencing. Leave all other jumpers in the factory-default positions.

Use the following procedure to configure your SCXI-1120/D module:

1. Configure the gains.

Each input channel has two user-configurable gain stages. The first gain stage provides gains of 1, 10, 50, and 100, and the second stage provides gains of 1, 2, 5, 10, and 20. Tables 3-4 and 3-5 show how to set up the gain for each channel.

Table 3-4. Gain Jumper Allocation

Input Channel Number	First Gain Jumper	Second Gain Jumper
0	W1	W9
1	W2	W10
2	W3	W11
3	W4	W12
4	W5	W13
5	W6	W14

Table 3-4. Gain Jumper Allocation (Continued)

Input Channel Number	First Gain Jumper	Second Gain Jumper
6	W7	W15
7	W8	W16

The SCXI-1120D has an additional fixed pre-stage gain of 0.5.

The SCXI-1120 is shipped with the first-stage gain set to 100 (position A), and a second-stage gain set to 10 (position D).

The SCXI-1120D is shipped with the first-stage gain set to 100 (position A), and the second-stage gain set to 20 (position E).

To change the gain of your module, move the appropriate jumper on your module to the position indicated in Table 3-5.

To determine the overall gain of a given channel on the SCXI-1120 use the following formula:

$$\text{Overall gain} = \text{First stage gain} \cdot \text{Second stage gain}$$

To determine the overall gain of a given channel on the SCXI-1120D use the following formula:

$$\text{Overall gain} = \frac{1}{2} \cdot \text{First stage gain} \cdot \text{Second stage gain}$$

Table 3-5. Gain Jumper Positions

Gain	Setting	Jumper Position
First-stage	1	D
	10	C
	50	B
	100	A (factory-default setting)

Table 3-5. Gain Jumper Positions (Continued)

Gain	Setting	Jumper Position
Second-stage	1	A
	2	B
	5	C
	10	D (factory-default setting for the SCXI-1120)
	20	E (factory-default setting for the SCXI-1120D)

2. Configure the filtering.

◆ **SCXI-1120 Filter Jumpers**

Two-stage filtering is also available on your SCXI-1120 module. The first stage is located in the isolated section of the input channel, whereas the second stage is located in the nonisolated section of your input channel. Two-stage filtering eliminates the noise generated by the isolation amplifier, producing a higher signal-to-noise ratio. Furthermore, two filter bandwidths are available, 10 kHz and 4 Hz.

Table 3-6. SCXI-1120 Filter Jumper Allocation

Input Channel Number	First Filter Jumper		Second Filter Jumper	
	4 Hz (Factory Default)	10 kHz	4 Hz (Factory Default)	10 kHz
0	W17-A	W17-B	W25	W26
1	W18-A	W18-B	W27	W28
2	W19-A	W19-B	W29	W30
3	W20-A	W20-B	W31	W32

Table 3-6. SCXI-1120 Filter Jumper Allocation (Continued)

Input Channel Number	First Filter Jumper		Second Filter Jumper	
	4 Hz (Factory Default)	10 kHz	4 Hz (Factory Default)	10 kHz
4	W21-A	W21-B	W33	W34
5	W22-A	W22-B	W35	W36
6	W23-A	W23-B	W37	W38
7	W24-A	W24-B	W39	W40

Your SCXI-1120 is shipped in the 4 Hz position. Verify that both stages are set to the same bandwidth to ensure that the required bandwidth is achieved. Notice that one jumper block is available for each filter stage.

◆ SCXI-1120D Filter Jumpers

Two-stage filtering is also available on your SCXI-1120D module. The first stage is located in the isolated section of the input channel, whereas the second stage is located in the nonisolated section of your input channel. Two-stage filtering eliminates the noise generated by the isolation amplifier, producing a higher signal-to-noise ratio. Furthermore, two filter bandwidths are available, 22.5 kHz and 4.5 kHz.

Table 3-7. SCXI-1120D Filter Jumper Allocation

Input Channel Number	First Filter Jumper		Second Filter Jumper	
	4.5 kHz (Factory Default)	22.5 kHz	22.5 kHz	4.5 kHz (Factory Default)
0	W17-A	W17-B	W25	W26
1	W18-A	W18-B	W27	W28
2	W19-A	W19-B	W29	W30

Table 3-7. SCXI-1120D Filter Jumper Allocation (Continued)

Input Channel Number	First Filter Jumper		Second Filter Jumper	
	4.5 kHz (Factory Default)	22.5 kHz	22.5 kHz	4.5 kHz (Factory Default)
3	W20-A	W20-B	W31	W32
4	W21-A	W21-B	W33	W34
5	W22-A	W22-B	W35	W36
6	W23-A	W23-B	W37	W38
7	W24-A	W24-B	W39	W40

Your SCXI-1120D is shipped in the 4.5 kHz position. Verify that both stages are set to the same bandwidth to ensure that the required bandwidth is achieved. Notice that one jumper block is available for each filter stage.

3. Configure the temperature sensor signal routing, if necessary.

Jumper W41 controls the routing of the temperature sensor signal available on the SCXI-1320 terminal block. Use position 1-2 (the factory-default position) for MTEMP (multiplexed) mode. Position 2-3 for DTEMP (direct) mode is no longer supported by the current version of the SCXI-1320 terminal block.

4. Configure the amplifier output referencing mode.

The signal output referencing is relevant only if you are connecting this SCXI-1120/D module directly to a DAQ device.

Use jumper W46 to configure the various referencing modes of the SCXI-1120/D instrumentation amplifier output. The correct output referencing mode depends on the input mode of the DAQ device you use.

Table 3-8 shows the signal referencing configurations for jumper W46.

Table 3-8. SCXI-1120/D Signal Referencing Jumper Configuration

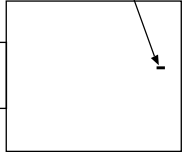
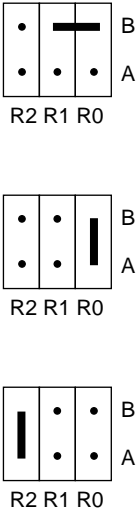
Jumper	Description	Configuration
	<p>B-R0R1—Parking position. Use this position for MIO or AI devices in DIFF input mode. (factory-default position).</p> <p>AB-R2—Select this position for AI or MIO devices in NRSE mode.</p> <p>AB-R0—Connects the PGIA reference to data acquisition analog ground, pins 1 and 2, of the rear signal connector. Use this position for DAQ devices with SE inputs, such as the Lab and 1200 devices, or MIO and AI devices in RSE mode.</p>	

- If you are using any digital SCXI modules in serial mode and want to connect the SCXI-1120/D module to the plug-in DAQ device, configure the SCXI-1120/D module to connect the MISO signal to the SERDATOUT pin (jumper W43).

SCXI-1121 Module

This module is a 4-channel isolation amplifier with excitation. Major features include four channels of isolated input, 1,500 V_{rms} isolation per channel, current or voltage excitation, an analog input range of ±5 V, 240 V_{rms} common-mode voltage, jumper-selectable lowpass three-pole RC filters with values of 4 Hz or 10 kHz, and individually configurable jumper-selectable channel gains of 1, 2, 5, 10, 20, 50, 100, 200, 500, 1,000, and 2,000.

The SCXI-1121 module has 45 user-configurable jumpers. Position the jumpers to configure gain, filtering, excitation mode, bridge completion, and signal output referencing. Leave all other jumpers in their factory-default positions.

The SCXI-1121 is factory-configured for use with an MIO or AI device in DIFF mode. Each module channel is configured for a gain of 1,000 (an input range of ± 5 mV), 4 Hz filtering, 3.33 V voltage excitation, and disabled bridge completion. If this configuration is suitable for your application, do not reposition any of the jumpers. However, you must adjust the jumper configuration if any of the following conditions is true:

- You are cabling the SCXI-1121 module directly to a DAQ device and you are using a Lab or 1200 device, or you are using an AI or MIO device in SE mode.
- You need a different gain or bandwidth (other than 1,000 and 4 Hz) on any channel.
- Your transducers require current excitation or 10.0 V voltage excitation.
- Your transducers require half-bridge completion circuitry.
- You are using digital modules and are cabling the SCXI-1121 to a DAQ device.

Read the rest of this section on the SCXI-1121 module if any of the previous conditions applies to you.

Use the following procedure to configure your SCXI-1121 module:

1. Configure the gain.

You select the gain for each SCXI-1121 channel in two stages, each of which is jumper controlled. The default gain for each channel is 1,000.

The total gain produced on a particular channel is equal to the product of the first-stage and second-stage gains applied to that channel, as shown by the following equation:

$$\text{Total gain (channel } n) = \text{first-stage gain (channel } n) \cdot \text{second-stage gain (channel } n)$$

The effective input range that you can measure with a particular gain is:

$$\text{Input range (V)} = \frac{\pm 5\text{V}}{\text{total gain}}$$

a. Configure the first-stage gain selection.

Use jumpers W3, W19, W29, and W41 to configure the first-stage gain of channels 0 through 3, respectively. Each jumper has four possible positions—A, B, C, and D—each corresponding to a particular gain.

- b. Configure the second-stage gain.

Use jumpers W4, W20, W30, and W42 to configure the second-stage gain of channels 0 through 3, respectively. Each of these jumpers has five possible positions—A, B, C, D, and E—each corresponding to a particular gain.

The jumper settings and corresponding gain values are listed in Tables 3-9 and 3-10.

Table 3-9. SCXI-1121 First-Stage and Second-Stage Gain Jumper Configuration

Input Channel Number	First-Stage Gain Jumper	Second-Stage Gain Jumper
0	W3	W4
1	W19	W20
2	W29	W30
3	W41	W42

Table 3-10. SCXI-1121 Gain Jumper Configuration

Gain	Setting	Jumper Position
First-stage	1	D
	10	C
	50	B
	100	A (factory setting)
Second-stage	1	A
	2	B
	5	C
	10	D (factory setting)
	20	E

- 2. Configure the filtering.

The filtering is also two-stage and is jumper-selectable for each channel. The SCXI-1121 uses a two-stage filtering configuration to achieve a higher signal-to-noise ratio. Filter bandwidth does not affect the maximum scanning rate. The factory-default jumper positions configures each channel for 4 Hz bandwidth.

- a. Configure the first-stage filtering.

Jumpers W5, W21, W31, and W43 select the first-stage filtering. Each of these jumpers has two positions—A and B. Position A selects the first stage of 4 Hz filtering, whereas position B selects the first stage of 10 kHz filtering.

- b. Configure the second-stage filtering.

Jumpers W6 through W13 select the second-stage filtering, which you must configure for the same frequency as that of the first stage. There are actually only four jumpers, as in the first stage; W6 through W13 correspond to eight positions, rather than eight jumpers. You can set each jumper to one of two positions. Setting the jumper to an even number (for example, W6) selects the second stage of 4 Hz filtering, whereas setting the jumper to an odd number (for example, W7) sets the second stage of the same channel to 10 kHz filtering. Refer to Table 3-11 for the jumper and channel correspondence for filtering.

Table 3-11. SCXI-1121 First-Stage and Second-Stage Filter Jumper Configuration

Input Channel Number	First-Filter Jumper		Second-Filter Jumper	
	4 Hz (Factory-Default)	10 kHz	4 Hz (Factory-Default)	10 kHz
0	W5-A	W5-B	W6	W7
1	W21-A	W21-B	W8	W9
2	W31-A	W31-B	W10	W11
3	W43-A	W43-B	W12	W13

3. Configure the excitation mode as current or voltage.

You can configure each SCXI-1121 excitation channel to produce voltage or current excitation. Strain gauges require voltage excitation, whereas RTDs and thermistors typically require current excitation. Each excitation channel has two jumpers to select the appropriate mode—W14, W15, W22, W23, W34, W35, W46, and W47.

Table 3-12 summarizes the excitation mode jumper settings. Notice that only position 1 is marked on the SCXI-1121 module. The factory-default excitation mode for each channel is voltage.

Table 3-12. SCXI-1121 Excitation Mode Jumper Configuration

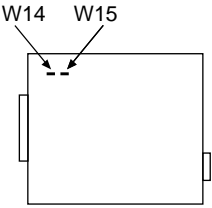
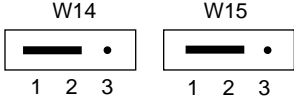
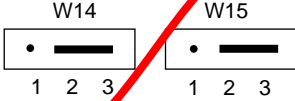
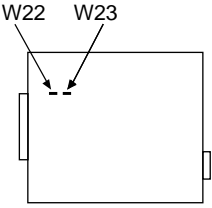
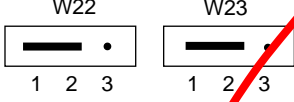
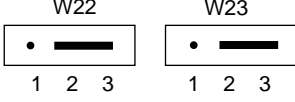
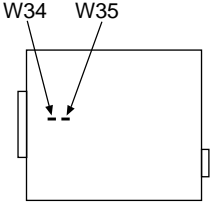
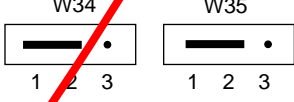
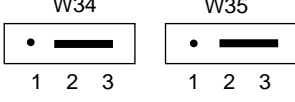
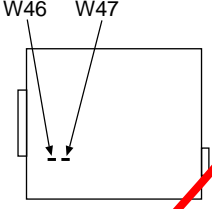
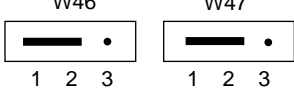
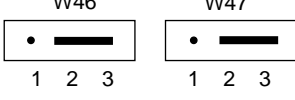
Jumpers	Excitation Channel	Voltage Mode (Factory-Default Position)	Current Mode
	0		
	1		
	2		
	3		

4. Configure the excitation level.

You can select the level of excitation applied to each excitation channel, again using two jumpers per channel—W16, W24, W25, W26, W36, W37, W48, and W49. If you select voltage mode, you can apply a potential difference of either 3.333 V or 10.00 V. If you select current mode, you can apply an excitation current of either 0.150 mA or 0.450 mA. Refer to the transducer specifications to determine the necessary excitation level. See Table 3-13 for the SCXI-1121 excitation level jumper settings, and refer to Table 3-14 for the maximum load per excitation channel.

Table 3-13. SCXI-1121 Excitation Level Jumper Configuration

Jumpers	Excitation Channel	3.333 V or 0.150 mA (Factory-Default Position)	10 V or 0.450 mA
	0		
	1		
	2		
	3		

Table 3-14. SCXI-1121 Maximum Load per Excitation Channel

Excitation Level	Maximum Load
3.333 V	28 mA
10 V	14 mA
0.150 mA	10 k Ω
0.450 mA	10 k Ω

5. Enable the half-bridge completion network, if necessary.

The SCXI-1121 includes a built-in half-bridge completion network to use with half-bridge or quarter-bridge transducers. The network includes two 4.5 k Ω ($\pm 0.05\%$) resistors, connected in series, with a temperature coefficient of 5 ppm/ $^{\circ}\text{C}$. You can enable the network on an individual channel basis using two additional jumpers per channel—W1, W2, W17, W18, W27, W28, W39, and W40. When you enable the completion network, you automatically remove access to the negative input of the amplifier to preserve overvoltage protection. See Table 3-15 for half-bridge completion network jumper information, and refer to Figures 4-5, 4-6, and 4-7 for diagrams of standard bridge configurations.

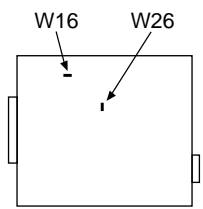
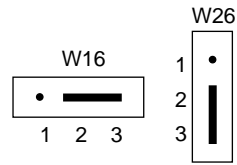
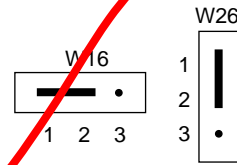
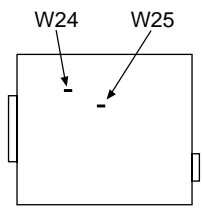
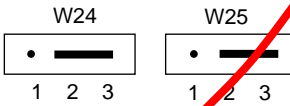
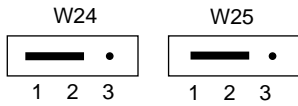
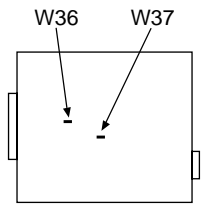
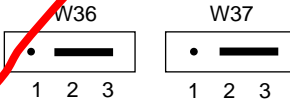
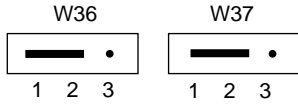
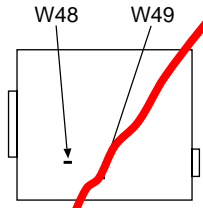
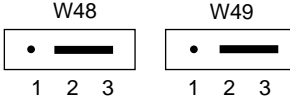
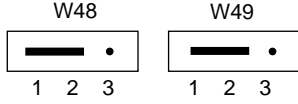
Table 3-15. SCXI-1121 Half-Bridge Completion Network Jumper Configuration

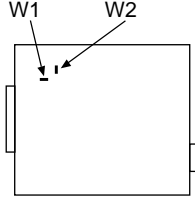
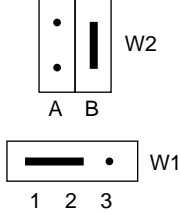
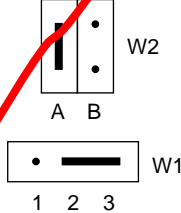
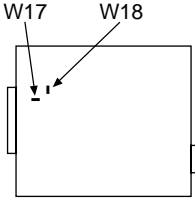
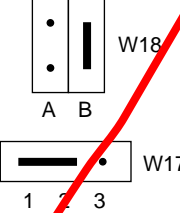
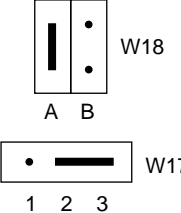
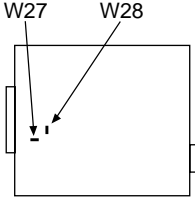
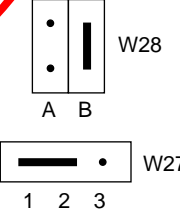
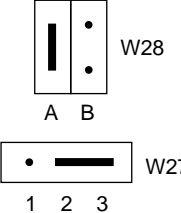
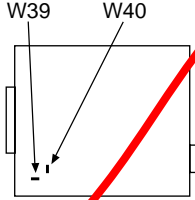
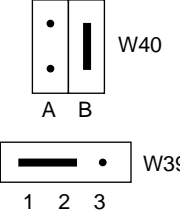
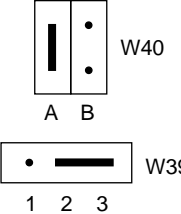
Jumpers	Channel	Enable Network	Disable Network (Factory-Default Position)
	0		
	1		
	2		
	3		

6. Configure the amplifier output referencing.

The signal output referencing is relevant only if you connect the SCXI-1121 module directly to a DAQ device.

Use jumper W33 to configure the various output referencing modes of the SCXI-1121 amplifier. The correct output referencing mode depends on the input mode of the DAQ device you use.

Table 3-16 shows the three possible signal referencing configurations.

Table 3-16. SCXI-1121 Amplifier Output Referencing Jumper Configuration

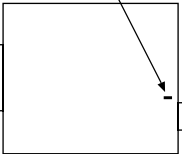
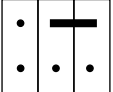
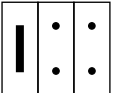
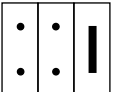
Jumper	Description	Configuration
 <p>W33</p>	A-R0R1—Parking position. Use this setting for MIO or AI devices in DIFF input mode (factory-default position).	 <p>R2 R1 R0</p>
	AB-R2—Select this position for AI and MIO devices in NRSE mode.	 <p>R2 R1 R0</p>
	AB-R0—Connects the amplifier reference to data acquisition analog ground, pins 1 and 2 of the rear signal connector. Use this position for DAQ devices with SE inputs, such as the Lab and 1200 devices, or MIO and AI devices in RSE mode.	 <p>R2 R1 R0</p>

7. If you are using any digital SCXI modules in serial mode and will connect the SCXI-1121 module to the plug-in DAQ device, configure the SCXI-1121 module to connect the MISO signal to the SERDATOUT pin (jumper W38).

SCXI-1122 Module

This module has 16 isolated input channels and two isolated excitation channels. The SCXI-1122 is a module for signal conditioning of strain gauges, RTDs, thermistors, thermocouples, volt and millivolt sources, 4 to 20 mA current sources, and 0 to 20 mA process-current sources. The SCXI-1122 can operate in two modes. Use the two-wire scan mode with all 16 input channels used for input or the four-wire scan mode with the eight upper channels configured as sense leads for connecting input channels and

the lower eight channels configured as current output channels. Other major features of this module include software-programmable gain and filtering, and the ability to account for voltage drop of long lead wires in strain-gauge measurement. The SCXI-1122 input signals are multiplexed to a single output, which drives a single DAQ device channel.

The SCXI-1122 has two jumpers. Jumper W2 connects a pullup resistor to the SERDATOUT signal on the rear signal connector as shown in Table 3-17. Jumper W1 configures the guard and the analog output ground and enables the NRSE mode. Filter bandwidth and scanning mode, both two-wire or four-wire, is software configured.



Use the following procedure to configure your SCXI-1122 module.



Note If the module is not connected to a DAQ device, the position of W2 is irrelevant.

1. When using a single chassis, set jumper W2 in position 1 on the SCXI-1122 that is connected to the DAQ device. When using multiple chassis, set jumper W2 to position 1 on only one of the SCXI-1122s that are cabled to the DAQ device. It does not matter which of the SCXI-1122s cabled to the DAQ device has the pullup connected. Set jumper W2 in position 3 on all of the other SCXI-1122 modules.

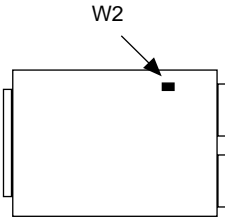
Table 3-17. SCXI-1122 Digital Signal Jumper Configurations

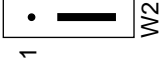
Jumper	Description	Configuration
	Position 1 (pullup)—Use this setting for a single-chassis system. Connects a 2.2 kΩ pullup resistor to the SERDATOUT line (factory-default position).	
	Position 3 (unmarked position, no pullup)—Use this setting for additional cabled SCXI-1122 modules in a multichassis system. No pullup resistor is connected to the SERDATOUT line.	

- The SCXI-1122 has one analog configuration jumper for grounding, shielding, and reference mode selection. Set jumper W1 as shown in Table 3-18.

Table 3-18. SCXI-1122 Analog Jumper Configuration

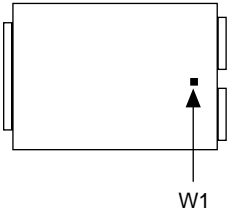
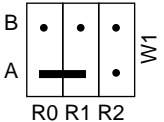
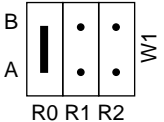
Jumper	Description	Configuration
 <p style="text-align: center;">W1</p>	A-R0R1—Parking position. Use this setting for MIO or AI devices in DIFF input mode (factory-default position).	
	AB-R0— Use this position for DAQ devices with SE inputs, such as the Lab and 1200 devices, or MIO and AI devices in RSE mode.	

Current-Loop Receivers

The SCXI-1122 includes provision for measuring current rather than voltage. National Instruments offers an SCXI process-current resistor pack, which consists of four 249 Ω , 0.1%, 5 ppm, 1/4 W resistors. For more information on how to install current loop receiver resistors, consult your *SCXI-1122 User Manual*.

Scanning Techniques



Note The SCXI-1122 input multiplexer is composed of relays. Relays have a certain life expectancy, as listed in Appendix A, *Specifications*, of the *SCXI-1122 User Manual*.

To avoid mechanical wear on the relays when the SCXI-1122 is used for continuous multichannel scanning, you should acquire n samples on a given channel before proceeding to the next channel, as shown in Figure 3-3b. For example, rather than performing 100 scans and taking a single sample from each channel during each scan, as shown in Figure 3-3a, acquire 100 samples from a channel then switch to the next channel and acquire a new set of samples, as shown in Figure 3-3b. The recommended method, software-driven scanning, saves relay life.

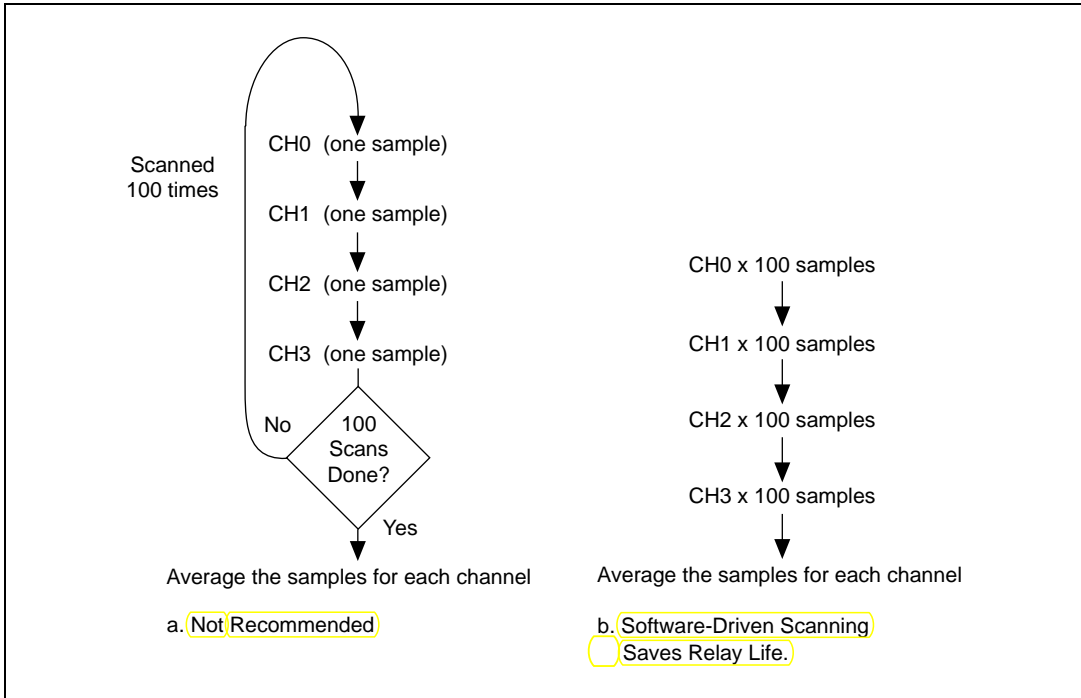

Figure 3-3. Scanning Techniques

SCXI-1124 Module

The SCXI-1124 has six isolated DACs with voltage or current outputs. The SCXI-1124 outputs are designed to generate DC or slowly-varying current or voltage signals, not waveforms.

The SCXI-1124 works with National Instruments AI and MIO devices, Lab and 1200 devices, and DIO devices. You can control several SCXI-1124s in a single chassis with one DAQ device and in combination with other SCXI module types.





Note If nothing is connected to the SCXI-1124 rear signal connector, the position of all of the jumpers is irrelevant.

If you cable this SCXI-1124 directly to a plug-in DAQ device, then use the following procedure to configure your SCXI-1124:

1. Set jumper W1 for a single chassis or multichassis system, as shown in Table 3-19.

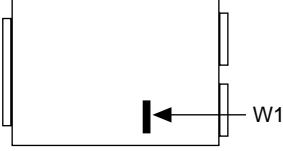
Table 3-19. SCXI-1124 Chassis Jumper Configuration

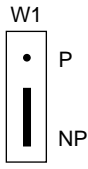
Jumper	Description	Configuration
	<p>Pullup—Use this setting for a single-chassis system. Connects a 2.2 kΩ pullup resistor to the SERDATOUT line (factory-default position).</p>	
	<p>No Pullup—Use this setting for additional cabled SCXI-1124 modules in a multichassis system. No pullup resistor is connected to the SERDATOUT line (parking position).</p>	

2. If you are cabling this module directly to a DAQ device, set jumpers W1, W2, and W3 depending on the type of DAQ device you are using, as shown in Table 3-20.

Table 3-20. SCXI-1124 Device-Type Jumper Configuration

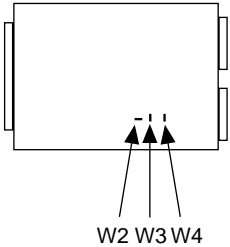
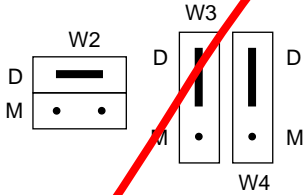
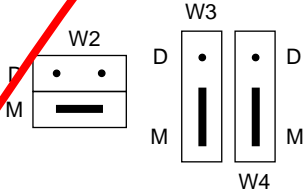
Jumper	Description	Configuration
	<p>D—Use this setting for all three jumpers if you want to connect the SCXI-1124 to a DIO device (factory-default position).</p>	
	<p>M—Use this setting for all three jumpers if you want to connect the SCXI-1124 to an MIO or Lab/1200 device.</p>	

You can connect two types of DAQ devices to the SCXI-1124—DIO devices and MIO devices. If you want to connect the SCXI-1124 to an MIO device, place jumpers W2, W3, W4 in the M position. If you are using an SCXI-1124 as well as modules with analog inputs, you should cable the MIO device to one of the analog input modules. The SCXI-1124 cannot route analog signals from the SCXibus to the MIO device.

SCXI-1125 Module

The SCXI-1125 module is exactly like the SCXI-1120/D with the exception that it is software configurable and does not have any jumpers. Use Measurement & Automation Explorer to configure the gain and filter settings for each channel. In addition, the SCXI-1125 only has support for the MTEMP configuration of the terminal block onboard temperature sensor.

SCXI-1126 Module

The SCXI-1126 is a signal conditioning module with eight isolated frequency input channels. Each channel of the SCXI-1126 includes a frequency to voltage conversion circuit with programmable input range, threshold, hysteresis, and filtering. Each channel is individually isolated with a working common-mode voltage of $250 V_{\text{rms}}$ between channels or channel to earth ground. The SCXI-1126 is software configurable and contains no jumpers.

SCXI-1140 Module

This module is an 8-channel simultaneously sampling differential amplifier. The SCXI-1140 has an instrumentation amplifier that can track and hold on all eight channels, an analog input range of $\pm 10 V$, and individual DIP-switch-selectable channel gains of 1, 10, 100, 200, and 500.

DAQ Device Connections in Multiple-Module Systems



Note If you use an SCXI-1140 in a system that contains multiple SCXI modules and one DAQ device, you must connect the SCXI-1140 to the DAQ device because the SCXI-1140 requires a counter/timer signal from the DAQ device to control the module track-and-hold circuitry. Other modules do not use this signal and thus do not route the signal to the SCXIbus.

If your system contains more than one SCXI-1140, the system operates correctly only when you have connected one of the SCXI-1140 modules to the DAQ device. Additional SCXI-1140 modules in the chassis can access the counter/timer signal using that module and the SCXIbus backplane. Other SCXI modules in the same chassis operate normally.

User-Configurable Jumpers and DIP Switches

This module has 10 user-configurable jumpers and eight DIP switches. You can use the jumpers and switches to configure input signal referencing, instrumentation amplifier output referencing, grounding, shielding, and gain. Leave all other jumpers in their factory-default positions.

The SCXI-1140 is factory-configured for use with an AI or MIO device in DIFF mode measuring ground-referenced signal sources—each module channel is configured for a gain of 1. If this configuration is suitable for your application, do not adjust any of the jumpers or DIP switches.

However, you must adjust the configuration if any of the following conditions is true:

- Your input signals are floating or nonreferenced.
- You are cabling this SCXI-1140 directly to a DAQ device and you are using a Lab/1200 device, or you are using an MIO or AI device in SE mode.
- You require a gain other than 1 on any channel.
- You are using digital modules and are cabling the SCXI-1140 to a DAQ device.

Read the rest of this section on the SCXI-1140 module if any of these conditions applies to you.

Use the following procedure to configure your SCXI-1140 module:

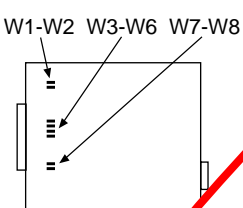
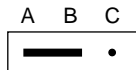
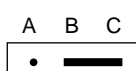

1. Configure the signal referencing modes. Table 3-21 lists the SCXI-1140 signal referencing configurations.

Table 3-21. SCXI-1140 Signal Referencing Jumper Configuration

Jumpers	Description	Configuration
	AB—Connects the instrumentation amplifier negative input to the front panel connector only (factory-default position). Use this setting to measure ground-referenced source signals.	
	BC—Connects instrumentation amplifier negative input to the front panel connector <i>and</i> to module analog ground through a 100 kΩ resistor (for floating sources). Use this setting to measure floating signals with this channel.	

2. Configure the instrumentation amplifier output referencing mode.
 The output referencing mode is relevant only if this SCXI-1140 is connected directly to a plug-in DAQ device. Table 3-22 lists the SCXI-1140 instrumentation amplifier signal referencing configurations.

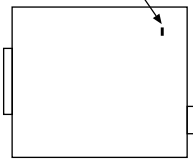
Table 3-22. SCXI-1140 Instrumentation Amplifier Jumper Configuration

Jumper	Description	Configuration
	AB—Use this setting for MIO or AI devices in DIFF mode (factory-default position).	
	BC—Use this position for DAQ devices with SE inputs such as the Lab and 1200 devices, or MIO and AI devices in RSE mode.	

Jumper W12 selects various grounding and shielding options. The factory-default position, CD, leaves the grounds disconnected and is suitable for most applications. For more information, refer to the *SCXI-1140 User Manual*.

3. Configure the gain selection.

Use the eight 4-bit DIP switches, U12 through U19, to select the gains of channels 0 through 7, respectively, as shown in Table 3-23. The factory-default position sets the gain to 1; that is, all four bits of each DIP switch are set to the off position (number side up). Select other gains by setting one or more of the four bits of a particular DIP switch to the on (closed) position as indicated in Table 3-24.

Table 3-23. SCXI-1140 Gain Switches for Each Channel

Channel	Use DIP Switch
0	U12
1	U13
2	U14
3	U15
4	U16
5	U17

Table 3-23. SCXI-1140 Gain Switches for Each Channel (Continued)

Channel	Use DIP Switch
6	U18
7	U19

Table 3-24. SCXI-1140 Switch Settings for Gain Selection

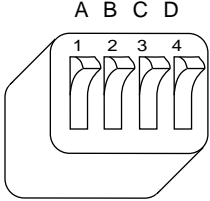
Switch	Desired Gain	Closed Switches
 <p>Switch is shown in factory-default (gain = 1) position.</p>	1	None
	10	D
	100	C
	200	B
	500	A

- If you are using any digital SCXI modules in serial mode and will connect the SCXI-1140 module to the DAQ device, configure the SCXI-1140 module to connect the MISO signal to the SERDATOUT pin (jumper W11). See the *SCXI-1140 User Manual* for details.

SCXI-1141, SCXI-1142, and SCXI-1143 Modules

The SCXI-1141, SCXI-1142, and SCXI-1143 have eight lowpass filters with differential input amplifiers. The filter types of the modules are elliptic, Bessel, and Butterworth, respectively. You can use the SCXI-1141, SCXI-1142, and SCXI-1143 for antialiasing applications as well as for general purpose amplification and filtering of signals.

The SCXI-1141, SCXI-1142, and SCXI-1143 have two user-configurable jumpers. Jumper W1 is set at the factory for a single-chassis system, and jumper W2 is set at the factory for a differential input DAQ device.



Note You need to change the SCXI-1141/1142/1143 jumper configuration only if or when you are using a multichassis system, when using a DAQ device in SE mode, or to change the default grounding and shielding configuration.

Jumper W1, when set to position P, connects a 2.2 k Ω pullup resistor to the SERDATOUT line. An open-collector driver drives the SERDATOUT line. An open-collector driver either actively drives low or goes to a high-impedance state, relying on a pullup resistor to make the signal line go high. If too many pullup resistors are attached to the SERDATOUT line, the drivers cannot drive the line low. To prevent this, set jumper W1 to position P on only one of the SCXI-1141/1142/1143 modules that are connected to the DAQ device in a multiple chassis system. It does not matter which of the SCXI-1141/1142/1143 modules that are cabled to the DAQ device has the pullup connected.

Tables 3-25 and 3-26 list the description and configuration of the configurable jumpers.

Table 3-25. SCXI-1141/1142/1143 Chassis Jumper Configuration

Jumper	Description	Configuration
	<p>Pullup—Use this position for a cabled module in a single-chassis system or the first chassis in a multichassis system (factory-default position).</p>	
	<p>No Pullup—Use this position for cabled modules in additional chassis in a multichassis system.</p>	

Table 3-26. SCXI-1141/1142/1143 Grounding and Shielding Jumper Configuration

Jumper	Description	Configuration
	Parking position. Use this setting with DAQ devices in DIFF mode (factory-default position).	
	Use this position for DAQ devices with SE inputs, such as the Lab and 1200 devices, DAQCard-700, or MIO and AI devices in RSE mode.	
	Connects the SCXibus guard to the analog reference.	
	Select this position for MIO and AI devices in NRSE mode.	

SCXI-1520 Module

The SCXI-1520 is an 8-channel module used to interface with strain gauges and strain-gauge-based sensors.

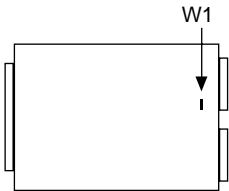
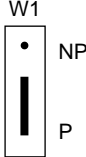
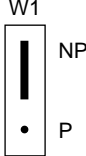
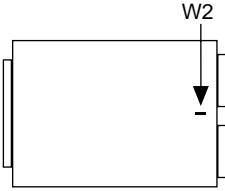
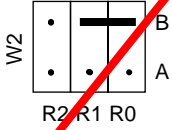
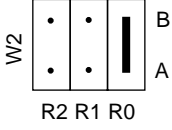
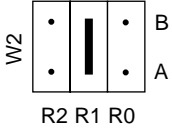
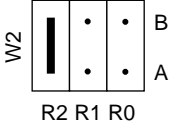
You can set the bridge excitation voltage, hardware null setting, filter cutoff frequency, or shunt calibration settings on a per-channel basis through software control. You can set the gain of each input channel through LabVIEW or NI-DAQ. An onboard EEPROM contains gain and offset calibration constants for each channel. NI-DAQ and LabVIEW automatically use these constants to correct for amplifier gain and offset errors when scaling data.

You can use direct function calls to NI-DAQ to configure and calibrate the SCXI-1520 as well as scale data acquired through the SCXI-1520. Table 3-27 lists these functions and describes their use.

Table 3-27. NI-DAQ Functions Applicable to the SCXI-1520

Function	Action
SCXI_Set_Gain	Sets the analog input gain within the allowable range of X1 to X1000.
SCXI_Set_Excitation	Sets bridge excitation voltage. Range is from 0 to 10 V in 0.625 V steps.
SCXI_Configure_Filter	Sets filter cutoff frequency to one of five settings: 10 Hz, 100 Hz, 1 kHz, 10 kHz, or bypass.
SCXI_Strain_Null	Automatically zero-nulls the sensor-induced offset voltage of the specified channel.
SCXI_Calibrate_Setup	Enables or disables shunt calibration on a per channel basis.
SCXI_Configure_Connection	Sets the bridge configuration to quarter, half, or full bridge.
SCXI_Calibrate	Initiates a module self-calibration. Updates the gain and offset constants stored in the EEPROM of the module. These constants are used by the scaling function SCXI_Scale.

The SCXI-1314 terminal block provides a convenient method of connecting field wiring from strain gauges and strain-gauge based sensors to the front signal connector of the SCXI-1520. The terminal block includes a socketed quarter-bridge completion resistor and two socketed shunt calibration resistors for each channel.

SCXI-1530/1531 Module

The SCXI-1530 and SCXI-1531 are four- and eight-channel modules, respectively, used for interfacing with Integrated Circuit Piezoelectric (ICP®) and other current-excited accelerometers. They have BNC connectors for direct connection to accelerometer cables. You can turn the 4 mA current excitation on or off. You can set the bandwidth of the four-pole Bessel filter to 2.5, 5, 10, or 20 kHz. You can set the gain to 1, 10, or 100X. All channels are simultaneously sampled and held to preserve timing and phase information. Excitation, bandwidth, and gain are set

on a per-channel basis without using jumpers. You configure the SCXI-1530/1531 using Measurement & Automation Explorer or through function calls to NI-DAQ.

SCXI-1540 Module

The SCXI-1540 module is an eight-channel module for interfacing to industry-standard LVDTs, RVDTs, and resolvers. It can accommodate a 4-wire or 5-wire connection to an LVDT, and it allows you to synchronize any number of channels to a common frequency. You can set the excitation level at 1 V_{rms} or 3 V_{rms}. You can set the excitation frequency at 2.5, 3.3, 5, or 10 kHz. You can set the gain over the range 0.8X to 25X to handle a wide range of LVDT sensitivities. Gain, level, frequency, and wire mode are set on a per-channel basis without the use of jumpers. You configure the SCXI-1540 using Measurement & Automation Explorer or through function calls to NI-DAQ.

Digital SCXI Modules

In addition to analog SCXI modules, National Instruments produces a variety of digital modules—the SCXI-1160, SCXI-1161, SCXI-1162, SCXI-1162HV, SCXI-1163, and SCXI-1163R. You can connect these modules to either an analog or a digital DAQ device. The digital modules can work with analog modules in the same chassis.

When you are working with both analog and digital modules, you must use an analog DAQ device because it can accept both analog and digital signals. You must also connect an analog module to the analog DAQ device because an analog module can transfer both analog and digital signals from the SCXIbus to the DAQ device.

The following sections describe each digital SCXI module and contain step-by-step instructions for configuring the jumpers on each module. Find the section about the module you want to configure. Check the position of each jumper and read the jumper position description. Change the appropriate jumpers to configure the module for your application.

Communication Modes

This section describes the serial and parallel communication modes.

Serial Mode

You can use any digital SCXI module in serial mode, in which you use a maximum of five digital lines to serially transfer data to and from the DAQ device. Either an analog or digital DAQ device can operate in serial mode, but an analog device works only in serial mode. Also, if you want to control a number of modules using any one DAQ device, you must configure all your digital modules for serial mode. The software configuration utilities use the multiplexed operating mode selection for digital modules to specify serial mode.

Parallel Mode

The SCXI-1162, SCXI-1162HV, SCXI-1163, and SCXI-1163R modules can work in parallel mode, in which you can use either 24 or 32 parallel lines to transfer data to or from a digital DAQ device. You must connect a module configured for parallel mode directly to a digital DAQ device. In parallel mode, you can use only one module per digital DAQ device; you must connect any other modules in the chassis, in either parallel or serial mode, to a different DAQ device. The only exception to this rule is the DIO-96/PnP, which can work with two digital modules in parallel mode or one module in parallel mode and any number in serial mode. If you connect a digital module to the second half (pins 51 through 100) of the NB5 cable connected to the DIO-96/PnP, you must select Parallel or Secondary operating mode in the Configuration window. No analog DAQ devices except the MIO-16D devices work with digital modules in parallel mode.



Note On the MIO-16D, the cable breaks out the 100-pin male I/O connector to two 50-pin female connectors. One 50-pin connector is equivalent to the MIO-16 I/O connector; the other 50-pin connector is equivalent to the DIO-24 I/O connector.

If you want to use your digital modules in serial mode, connect one module to the MIO-16-equivalent half of the NB5 cable and use the MIO-16D as an analog device.

If you want to use parallel mode with the SCXI-1162 or SCXI-1163, connect the SCXI module to the PC-DIO-24-equivalent half of the cable and use the MIO-16D as a digital device. If you use the DIO-24-equivalent half of the cable, you must select the parallel (secondary) operating mode in Measurement & Automation Explorer.

SCXI-1160 Module

This module controls 16 isolated SPDT relays. The module has three user-configurable jumpers for configuring the type of DAQ device connected to your module. Leave all other jumpers in the factory-default positions.

The SCXI-1160 module is shipped configured for use with a DIO device.



Note If you are not connecting the SCXI-1160 module directly to a DAQ device, you do not need to change any jumper settings.

If you are connecting the SCXI-1160 directly to a DAQ device, set jumpers W2, W3, and W4 according to whether the module is connected to an analog device or a DIO device as shown in Table 3-28.

Table 3-28. SCXI-1160 Device-Type Configuration

Jumper	Description	Configuration
<p style="text-align: center;">W2 W3 W4</p>	<p>DIO—Use this setting to connect the SCXI-1160 to a DIO device (factory-default position).</p>	
	<p>MIO—Use this setting if you connect your SCXI-1160 to an AI or MIO device, or a Lab/1200 device.</p>	

SCXI-1161 Module

The SCXI-1161 module controls eight SPDT relays. The module has three user-configurable jumpers for configuring the type of DAQ device connected to your module. Leave all other jumpers in the factory-default positions.

The SCXI-1161 module is shipped configured for use with a DIO device.



Note If you are not connecting the SCXI-1161 module directly to a DAQ device, you do not need to change any jumper settings.

If you are connecting the SCXI-1161 directly to a DAQ device, set jumpers W3, W4, and W5 according to whether the module is connected to an analog device or a DIO device as shown in Table 3-29.

Table 3-29. SCXI-1161 Device-Type Configuration

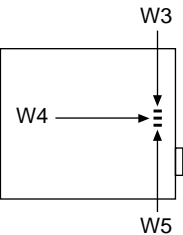
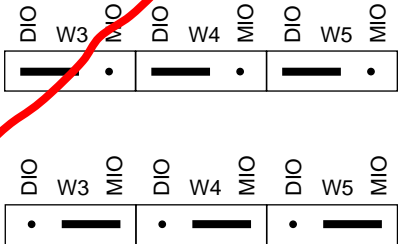
Jumper	Description	Configuration
	<p>DIO—Use this setting to connect the SCXI-1161 to a DIO device (factory-default position).</p> <p>MIO—Use this setting if you connect your SCXI-1160 to an AI or MIO device or Lab /1200 device.</p>	

SCXI-1162 Module

This module has 32 optically-isolated digital input channels. Major features include 450 V_{rms} isolation, 1,900 V_{rms} breakdown, TTL and CMOS compatibility, and high-speed parallel data transfer to digital DAQ devices. The module has four user-configurable jumpers for configuring the operating mode and the type of DAQ device connected to your module. Leave all other jumpers in the factory-default positions.

The SCXI-1162 module is shipped configured for use with a DIO device in serial mode.



Note You need to adjust jumpers on this module only if you connect the module directly to an analog DAQ device or use the module in parallel mode. If either of these conditions applies to you, read the rest of this section.

Use the following procedure to configure your SCXI-1162 module:

1. Select parallel or serial mode.

Use jumper W2 to select whether the module transfers data in parallel to a digital DAQ device (or the DIO-24 connector of an MIO-16D device) or serially to either a digital or an analog DAQ device. For more information see Table 3-30. If you use parallel mode, you must also set the number of parallel lines using jumper W1.

Table 3-30. SCXI-1162 Communication Mode Configuration

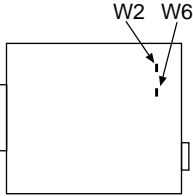
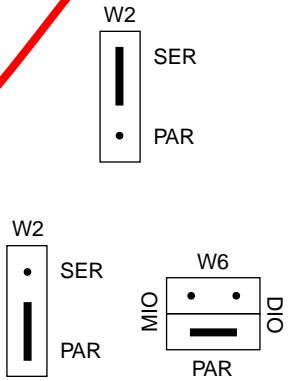
Jumper	Description	Configuration
	<p>SER—Use this setting to configure the rear connector for serial communication (factory-default position).</p> <p>PAR—Use this setting to configure the rear connector for parallel communication.</p>	

2. Select 24 or 32 lines.

If jumper W2 is set to parallel mode, you can use jumper W1 to select whether the module transfers 24 or 32 parallel lines of data to the device. If you are using a DIO-24 or the digital connector (pins 51 through 100) of an MIO-16D, you must select 24 lines. If you are using a DIO-32 or a DIO-96/PnP, select 32 lines. If you are using an analog DAQ device, set jumper W2 to the serial position, which makes the position of W1 irrelevant. For more information see Table 3-31.

Table 3-31. SCXI-1162 Parallel Lines Jumper Configuration

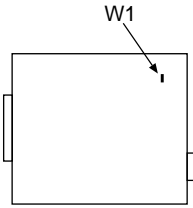
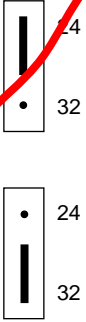
Jumper	Description	Configuration
	<p>24—Use this setting to drive only 24 rear connector data lines when W2 is set to PAR (factory-default position).</p> <p>32—Use this setting to drive all 32 rear connector data lines when W2 is set to PAR.</p>	

3. Select your device type—either analog or digital.

If this module is connected *directly* to a DAQ device, jumpers W3, W4, and W6 specify to which type of device the module is connected. Set jumpers W3, W4, and W6 to the DIO position if the module is connected to a DIO-24, DIO-32, or DIO-96/PnP device. Set the jumpers to the MIO position if the module is connected to an AI or MIO device or Lab/1200 device. If you are using the SCXI-1162 in parallel mode, set jumper W6 to the PAR position. If the module is not connected directly to a DAQ device, the positions of W3, W4, and W6 are irrelevant.

Table 3-32 shows the SCXI-1162 device-type jumper configurations.

Table 3-32. SCXI-1162 Device-Type Jumper Configuration

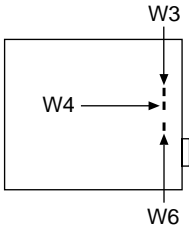
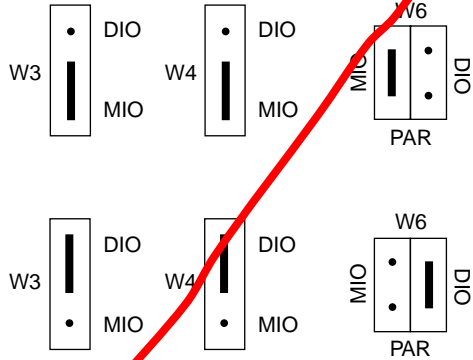
Jumper	Description	Configuration
	<p>MIO—Use this setting to configure the rear connector for an AI or MIO device or Lab/1200 device in serial mode (factory-default position).</p> <p>DIO—Use this setting to configure rear connector for a DIO device in serial mode.</p>	

SCXI-1162HV Module

The SCXI-1162HV module consists of 32 optically-isolated, wide range, AC or DC digital inputs. The SCXI-1162HV is a module used for sensing the presence of AC or DC voltages.

To configure the SCXI-1162HV module, use the six user-configurable jumpers (W2–W7). (Jumper W1 is a reserved jumper and should remain unconnected.)



Note If you are controlling the SCXI-1162HV through the SCXIbus and are not connecting a DAQ device directly to the rear connector of the SCXI-1162HV, the positions of these jumpers are irrelevant.

Jumper W3, when set to position P, connects a 2.2 kΩ pullup resistor to the SERDATOUT line. An open-collector driver either actively drives low or goes to a high-impedance state, relying on a pullup resistor to make the signal line go high. If too many pullup resistors are attached to the SERDATOUT line, the drivers cannot drive the line low. To prevent this, set jumper W3 to position P on only one of the SCXI-1162HV modules cabled to the DAQ device in a multichassis system. It does not matter which of the SCXI-1162HV modules cabled to the DAQ device has the pullup connected.

Table 3-33 lists the description and configuration of the user-configurable jumpers.

Table 3-33. SCXI-1162HV Jumper Configuration

Jumper	Description	Configuration
 <p>W5</p>	24—Use this setting to drive only 24 lines when W2 is set to PAR and you are using a DIO-24 or an MIO-16D device (factory-default position).	
	32—Use this setting to drive all 32 rear connector data lines when W2 is set to PAR and you are using a DIO-32 or DIO-96/PnP device.	
 <p>W6</p>	S—Use this setting to configure the rear connector for serial communication (factory-default position).	
	P—Use this setting to configure the rear connector for parallel communication. Use with DIO devices only.	
 <p>W7</p>	DIO—Use this setting to configure the rear connector for a DIO device (factory-default position).	
	MIO—Use this setting to configure the rear connector for an MIO device. Includes AI or MIO device or Lab/1200 device.	
 <p>W4</p>	DIO—Use this setting to configure the rear connector for a DIO device (factory-default position).	
	MIO—Use this setting to configure the rear connector for an MIO device. Includes AI or MIO device or Lab/1200 device.	

Table 3-33. SCXI-1162HV Jumper Configuration (Continued)

Jumper	Description	Configuration
 <p>W3</p>	<p>Pullup—Use this setting for a single-chassis system or for the first chassis in a multichassis system. Connects a pullup resistor to the SERDATOUT line (factory-default position).</p>	
	<p>No Pullup—Use this setting for additional chassis in a multichassis system. No pullup resistor is connected to the SERDATOUT line.</p>	
 <p>W2</p>	<p>DIO—Use this setting to configure SERDATOUT for DIO devices (factory-default position).</p>	
	<p>MIO—Use this setting to configure SERDATOUT for MIO device. Includes AI or MIO device or Lab/1200 device.</p>	
	<p>PAR—Use this setting to disconnect SERDATOUT line. Use for parallel mode.</p>	

SCXI-1163 Module

This module is a 32-channel optically isolated digital output module with TTL and CMOS compatibility, 450 V_{rms} isolation and 1,900 V_{rms} breakdown, and high-speed parallel data transmission from digital DAQ devices. The module has five user-configurable jumpers for configuring the operating mode and the type of DAQ device connected to your module. Leave all other jumpers in the factory-default positions.

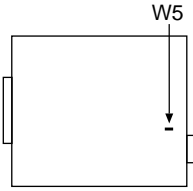
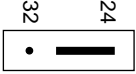
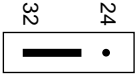
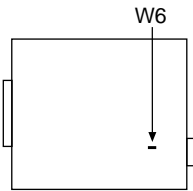
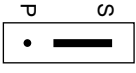
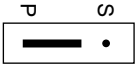
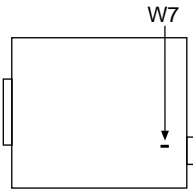
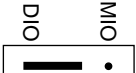
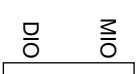
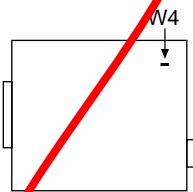
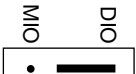
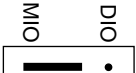
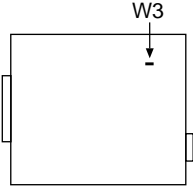
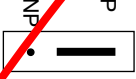
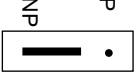
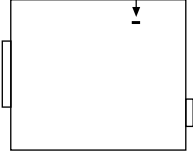
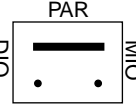
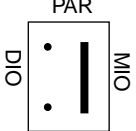
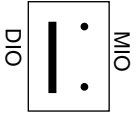
The SCXI-1163 module is shipped configured for use with a DIO device in serial mode.



Note You need to adjust jumpers on this module only if you plan to connect the module directly to an analog DAQ device or if you want to use the module in parallel mode. If either of these conditions applies to you, read the rest of this section.

Use the following procedure to configure your SCXI-1163 module:

1. Select your device type—either analog or digital.

If the module is connected to a DIO device, set jumpers W2 and W3 to the DIO position, as shown in Table 3-34. If the module is connected to an analog device, set W2 and W3 to the MIO position. If the module is not cabled *directly* to a DAQ device, the positions of W2 and W3 are irrelevant.

Table 3-34 shows the SCXI-1163 device-type jumper configurations.

Table 3-34. SCXI-1163 Device-Type Jumper Configuration



Jumper	Description	Configuration
	<p>DIO—Use this setting to configure the rear connector for a DIO device in serial mode (factory-default position).</p>	
	<p>MIO—Use this setting to configure the rear connector for an AI or MIO or Lab/1200 device.</p>	

2. Select serial or parallel mode.

If you are using the module in parallel mode, set jumper W6 to the P position and jumper W5 to the PAR position. For serial mode, set W6 to the S position and jumper W5 to the MIO or DIO position, depending on the type of DAQ device to which the module is connected. If you are using the module in parallel mode, it must be directly connected to a digital DAQ device or the DIO-24 connector of an MIO-16D.

Table 3-35 shows the SCXI-1163 mode jumper configurations.

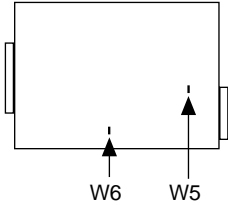
Table 3-35. SCXI-1163 Mode Jumper Configuration

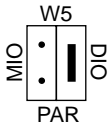
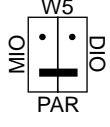
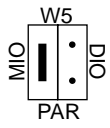
Jumper	Description	Configuration
	<p>S—Use this setting to configure the module in serial mode (factory-default position).</p>	
	<p>P—Use this setting to configure the rear connector for a DIO device in parallel mode.</p>	
	<p>DIO—Use this setting to configure the module in serial mode (factory-default position).</p>	
	<p>PAR—Use this setting to configure the rear connector for a DIO device in parallel mode.</p>	
	<p>MIO—Use this setting to configure the rear connector for an MIO device.</p>	

SCXI-1163R Module

The SCXI-1163R is an SCXI module consisting of 32 optically-isolated solid-state relays. The SCXI-1163R module switches loads up to 240 V_{rms} or VDC and 200 mA.

The SCXI-1163R operates in serial mode with MIO and AI devices, Lab/1200 devices, and DIO devices. You can control several SCXI-1163R modules in serial mode in a single chassis with one DAQ device.

Alternatively, you can control 24 of the solid-state relays in parallel mode with a DIO-24, or all 32 solid-state relays in parallel mode with a DIO-32 or DIO-96/PnP.



Note You should change the jumper configuration from the factory-default settings only if you plan to connect the SCXI-1163R directly to an MIO and AI device, or if you plan to use the SCXI-1163R in parallel mode.

Tables 3-36 and 3-37 show the SCXI-1163R jumper configurations.

Table 3-36. SCXI-1163R Device-Type Jumper Configuration







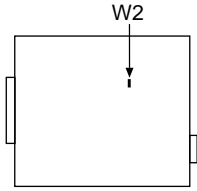

Jumper	Description	Configuration for DIO Device	Configuration for MIO Device
 <p>W2</p>	<p>Configures rear connector. Factory-default position is for DIO devices.</p>		
 <p>W3</p>	<p>Configures rear connector. Factory-default position is for DIO devices.</p>		
 <p>W5</p>	<p>Configures SERDATOUT line for a DIO or MIO device. Factory-default position is for DIO devices.</p> <p>PAR—Use this setting to disconnect SERDATOUT line and for parallel mode.</p>	 	

Table 3-37. SCXI-1163R Chassis and Mode Jumper Configuration

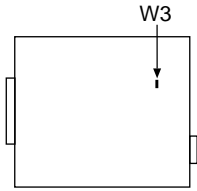
Jumper	Description	Configuration
 <p>W4</p>	A—Use this setting for a single-chassis system (factory-default position).	
	B—Use this setting for an additional chassis in a multichassis system.	
 <p>W6</p>	S—Sets communication mode to serial (factory-default position).	
	P—Sets communication mode to parallel.	

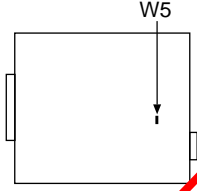
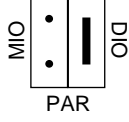
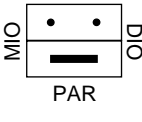
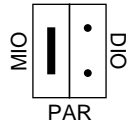
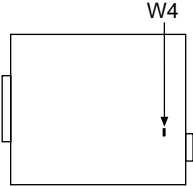
Jumper W4, when set to position A, connects a 2.2 k Ω pullup resistor to the SERDATOUT line. An open-collector driver drives the SERDATOUT line. An open-collector driver either actively drives low or goes to a high-impedance state, relying on a pullup resistor to make the signal line go high. If too many pullup resistors are attached to the SERDATOUT line, the drivers cannot drive the line low. To prevent this, set jumper W4 to position A on only one of the SCXI-1163R modules that are connected to the DAQ device in a multichassis system. It does not matter which of the SCXI-1163R modules cabled to the DAQ device has the pullup connected.

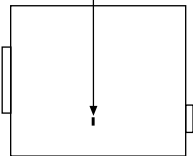
SCXI-1200 Module

The SCXI-1200 controls the operation of and digitizes the conditioned analog signals from other SCXI modules. The SCXI-1200 has eight analog input channels, which can be configured as eight SE or four DIF; a 12-bit successive-approximation ADC; two 12-bit DACs with voltage outputs; 24 lines of TTL-compatible digital I/O; and 16-bit counter/timer channels for timing I/O.

You can use the SCXI-1200 module in two types of configurations:

- connecting the SCXI-1200 module directly to the parallel port of the computer
- connecting the SCXI-1200 to the parallel connector of the SCXI-2000 or SCXI-2400 for connection to RS-232 or RS-485 serial ports.

The SCXI-1200 complies with the IEEE 1284 parallel port standard. This IEEE protocol supports three different parallel port types—the original Centronics or unidirectional port for printers, the PS/2 type bidirectional port, and the 386-SL Enhanced Parallel Port (EPP).

Parallel Port Interface

If you plan to connect the SCXI-1200 directly to the parallel port of your computer, read this section carefully.

An IBM-compatible computer can support up to three parallel printer ports, which are designated LPT1, LPT2, and LPT3. Each port uses three consecutive I/O addresses. When you power up your system, DOS assigns the printer ports to the logical LPT designations in the following order—LPT1, LPT2, and LPT3. The starting addresses of the parallel printer ports, in the order assigned to LPT designations, are 3BC, 378, and 278 hex. Therefore, if you have installed all three ports, 3BC hex is LPT1, 378 hex is LPT2, and 278 hex is LPT3. If you have not installed port 3BC hex, port 378 hex becomes LPT1 and port 278 hex becomes LPT2. If only one parallel port is present, it is LPT1.

The SCXI-1200 can use the parallel port hardware interrupts for interrupt-driven data acquisition. Interrupt levels 7 and 5 are commonly used for parallel ports. Refer to your parallel port reference manual for details about interrupt selection.

When you use the SCXI-1200, you must know which port and interrupt channel is being used. If you use the SCXI-1200 with NI-DAQ software, however, you select the port and interrupt at configuration time.

If you are using the SCXI-1200 in an SCXI-2000 chassis or with an SCXI-2400 module with RS-232/RS-485 communications, you do not need to be concerned with parallel port addresses and interrupts.

Module Configuration

The SCXI-1200 is software calibrated and software configurable. The SCXI-1200 has one reserved jumper that selects the grounding scheme for the SCXIbus guard.

Analog I/O Configuration

The SCXI-1200 is shipped from the factory with the following configuration:

- RSE input mode
- ± 5 V analog input range (bipolar)
- ± 5 V analog output range (bipolar)

Table 3-38 lists all the available analog I/O configurations for the SCXI-1200 and shows the factory settings.

Table 3-38. SCXI-1200 Analog I/O Settings

Parameter	Configuration
Analog Output CH0 Polarity	Bipolar— ± 5 V (factory setting) Unipolar—0 to 10 V
Analog Output CH1 Polarity	Bipolar— ± 5 V (factory setting) Unipolar—0 to 10 V
Analog Input Range	Bipolar— ± 5 V (factory setting) Unipolar—0 to 10 V
Analog Input Mode	RSE (factory setting) NRSE DIFF

Both the analog input and analog output circuits are software configurable.

Analog Output Configuration

The SCXI-1200 has two channels of analog output voltage available at the front I/O connector. You can configure each analog output channel for either unipolar or bipolar output. A unipolar configuration has a range of 0 to 10 V at the analog output. A bipolar configuration has a range of -5 V to $+5$ V at the analog output. In addition, you can select the coding scheme for each DAC as either two's complement or straight binary.

If you select a bipolar range for a DAC, the two's complement coding is recommended. In this mode, data values written to the analog output channel range from F800 hex ($-2,048$ decimal) to 7FF hex ($2,047$ decimal). If you select a unipolar range for a DAC, the straight binary coding is recommended. In this mode, data values written to the analog output channel range from 0 to FFF hex ($4,095$ decimal).

Analog Input Configuration

The SCXI-1200 has three different input modes—RSE, NRSE, and DIFF. The single-ended input configurations provide eight channels. The DIFF input configuration provides four channels. Table 3-39 describes these configurations.

Table 3-39. SCXI-1200 Analog Input Configurations

Configuration	Description
RSE	RSE configuration provides eight single-ended inputs with the negative input of the instrumentation amplifier referenced to analog ground (factory setting).
NRSE	NRSE configuration provides eight single-ended inputs with the negative input of the instrumentation amplifier tied to AISENSE/AIGND and not connected to ground.
DIFF	DIFF configuration provides four differential inputs with the positive input of the instrumentation amplifier tied to channels 0, 2, 4, or 6 and the negative input tied to channels 1, 3, 5, or 7, respectively, thus choosing channel pairs (0, 1), (2, 3), (4, 5), or (6, 7).

RSE Input (Eight Channels, Factory Setting)

RSE input means that all input signals are referenced to a common ground point that is also tied to the SCXI-1200 analog input ground. The instrumentation amplifier negative input is tied to analog ground. The RSE configuration is useful for measuring floating signal sources. With this input configuration, the SCXI-1200 can monitor eight different analog input channels.

Considerations for using the RSE configuration are discussed in the *SCXI-1200 User Manual*. Notice that in this mode the return path of the signal is analog ground at the connector through the AISENSE/AIGND pin.

NRSE Input (Eight Channels)

NRSE input means that all input signals are referenced to the same common-mode voltage, which floats with respect to the SCXI-1200 analog ground. This common-mode voltage is subsequently subtracted by the input instrumentation amplifier. The NRSE configuration is useful for measuring ground-referenced signal sources.

Considerations for using the NRSE configuration are discussed in the *SCXI-1200 User Manual*. Notice that in this mode, the return path of the signal is through the negative terminal of the amplifier at the connector through the AISENSE/AIGND pin.



Note To measure the conditioned signals provided by analog input modules in the same chassis, the SCXI-1200 must be configured for NRSE input mode.

DIFF Input (Four Channels)

DIFF input means that each input signal has its own reference, and the difference between each signal and its reference is measured. The signal and its reference are each assigned an input channel. With this input configuration, the SCXI-1200 can monitor four differential analog input signals.

Considerations for using the DIFF configuration are discussed in the *SCXI-1200 User Manual*. Notice that the signal return path is through the negative terminal of the amplifier and through channel 1, 3, 5, or 7, depending on which channel pair you select.

Analog Input Polarity and Range Configuration

You can select the analog input on the SCXI-1200 for either a unipolar range (0 to 10 V) or a bipolar range (–5 to +5 V). The range and the coding scheme are both software-selectable. In addition, you can select the coding scheme for analog input as either two's complement or straight binary. If you select a bipolar range, the two's complement coding is recommended. In this mode, –5 V input corresponds to F800 hex (–2,048 decimal) and +5 V corresponds to 7FF hex (2,047 decimal). If you select a unipolar mode, the straight binary coding is recommended. In this mode, 0 V input corresponds to 0 hex, and +10 V corresponds to FFF hex (4,095 decimal).

Table 3-40 describes the jumper settings for different configurations.

Table 3-40. SCXI-1200 Jumper Configuration







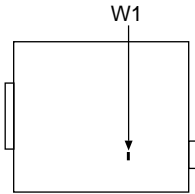

Jumper	Description	Configuration
	<p>AB—The SCXI analog bus guard is not connected to the SCXI-1200 analog ground. Use this setting when using the SCXI-1200 in standalone mode (factory-default position).</p>	<p>A  NC B  Guard C  Guard</p>
	<p>BC—The SCXI analog bus guard is connected to the SCXI-1200 analog ground. Use this setting when using the SCXI-1200 in conjunction with other analog input modules in the same chassis.</p>	<p>A  NC B  Guard C  Guard</p>

Figure 3-4 shows the SCXI-1200 front connector pin assignments.

ACH0	1	2	ACH1
ACH2	3	4	ACH3
ACH4	5	6	ACH5
ACH6	7	8	ACH7
AISENSE/AIGND	9	10	DAC0OUT
AGND	11	12	DAC1OUT
DGND	13	14	PA0
PA1	15	16	PA2
PA3	17	18	PA4
PA5	19	20	PA6
PA7	21	22	PB0
PB1	23	24	PB2
PB3	25	26	PB4
PB5	27	28	PB6
PB7	29	30	PC0
PC1	31	32	PC2
PC3	33	34	PC4
PC5	35	36	PC6
PC7	37	38	EXTTRIG
EXTUPDATE*	39	40	EXTCONV*
OUTB0	41	42	GATB0
COUSB1	43	44	GATB1
CCLKB1	45	46	OUTB2
GATB2	47	48	CLKB2
+5 V	49	50	DGND

Figure 3-4. SCXI-1200 Front Connector Pin Assignments

SCXI-1180 Feedthrough Panel

You can use the SCXI-1180 feedthrough panel, in conjunction with an SCXI cable assembly, to route signals from the front connector of the SCXI-1180 to a 50-pin I/O connector on the SCXI cable assembly. With the SCXI-1180, you can integrate signals that do not require conditioning into the SCXI chassis and use channels that the chassis is not already using. This is useful if you need to use the DAQ device analog output channels or connect unconditioned signals to unused analog input channels.

For example, the SCXI-1100 drives only two of the DAQ device analog input channels, channel 0 and channel 1; if you connect an SCXI-1100 module to a DAQ device, channels 2 through 7 remain available for use with unconditioned signals. You should always install the SCXI-1180 panel in the SCXI chassis slot immediately to the right of the SCXI module connected to the DAQ device to ensure easy connection to the cable assembly. Other uses for the SCXI-1180 are described in the *SCXI-1180/1181 User Manual*.

SCXI-1181 Breadboard Module

The SCXI-1181 module has a breadboard area for integrating custom circuitry into the SCXI system. Refer to the *SCXI-1180/1181 User Manual* for more information.

SCXI-2400 Serial Communications Module

The SCXI-2400 serial communications module adds RS-232 and RS-485 serial communications to any SCXI chassis, including the SCXI-1000, SCXI-1000DC, and SCXI-1001 chassis. You can either connect the SCXI-2400 module directly to the RS-232 serial COM port of a computer, or you can connect the SCXI-2400 module to an RS-485 network for long-distance, multidrop configurations.

If your SCXI chassis includes any analog input modules, the chassis must include the SCXI-1200 DAQ module to digitize the unconditioned analog signals. The digitized data, available on the rear parallel connector of the SCXI-1200, is communicated to the SCXI-2400 using the short parallel port cable provided with the SCXI-2400 module. Therefore, you should install the SCXI-1200 module in a slot adjacent to the SCXI-2400 module.

The SCXI-2400 also includes a connector adapter assembly that provides the parallel port connector and RS-485 connection. After installing the SCXI-2400 module into the SCXI chassis, attach this connector adapter to the rear of the SCXI-2400 through the back opening of the SCXI chassis. Screw down the connector adapter for secure cabling.

Baud Rate and Address Configuration

The SCXI-2400 includes DIP switches on the front panel to select the baud rate for serial communication and the address when used with an RS-485 connector.

The SCXI-2400 is shipped with a default baud rate of 9600 bps and a chassis address of 1. These switch settings are shown in Figure 3-5. Leave the DIP switches in these settings for initial configuration. After establishing communications with the computer, you can increase the baud rate (up to 57.6 kbps) and, if using an RS-485 connector with multiple chassis, change the address. See the *SCXI-2400 User Manual* for more information about changing the baud rate and address.

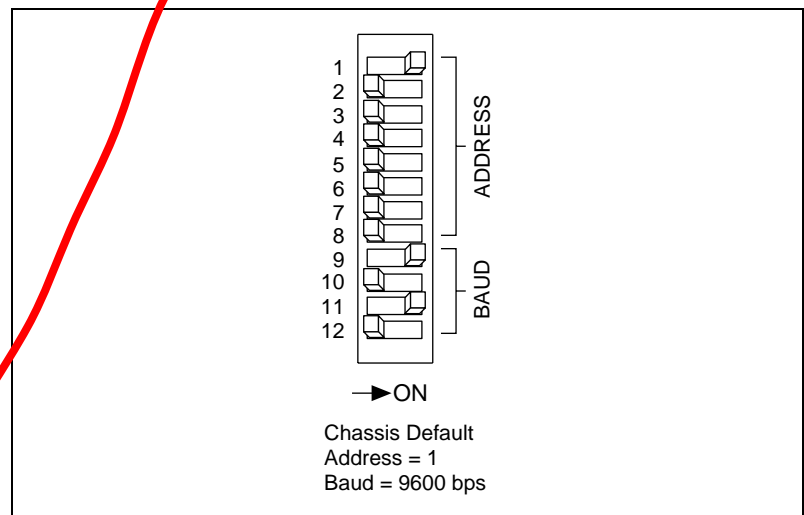

Figure 3-5. SCXI-2400 Module Default Switch Settings

SCXI Chassis

This section describes the SCXI-2000 chassis with serial communication and the SCXI-1000, SCXI-1000DC, and SCXI-1001 Chassis.

SCXI-2000 Chassis with Serial Communications

The SCXI-2000 is a four-slot chassis with built-in RS-232 and RS-485 serial communication. You can connect the SCXI-2000 chassis directly to a RS-232 serial COM port on a computer, or you can connect the SCXI-2000 chassis to an RS-485 network for long distance, multidrop configurations.

If your SCXI chassis includes any analog input modules, the SCXI-2000 chassis must include the SCXI-1200 DAQ module to digitize the conditioned analog signals. The digitized data is routed to the SCXI-2000 using the 7 in. IEEE 1284 parallel port cable provided with the SCXI-2000 module. Therefore, you should install the SCXI-1200 module into slot 1 of the chassis.

Baud Rate and Address Configuration

The SCXI-2000 includes DIP switches on the front panel. Select the baud rate for serial communication and the address (when used with an RS-485 connector).

The SCXI-2000 is shipped with a default baud rate of 9600 bps and a chassis address of 1. You should leave the DIP switches in these settings for initial configuration. After establishing communications with the computer, you can increase the baud rate (up to 57.6 kbps) and, if you are using an RS-485 network with multiple chassis, change the address. See your SCXI chassis user manual for more information about changing the baud rate and address.

SCXI-1000, SCXI-1000DC, and SCXI-1001 Chassis

The SCXI-100X chassis house four or twelve SCXI modules. The only configuration you must make is to set the chassis address for the SCXI-100X chassis when you are connecting more than one chassis to a single DAQ device. If you are configuring a multichassis system with a DAQ device, refer to your SCXI chassis user manual for instructions on how to change the chassis address.

Configure Your Software for Use with SCXI Products

Before you can configure your software, you must install it. Refer to *Installing Your Software* in Chapter 2, *Installing SCXI Modules and Connecting the SCXI System to the DAQ Device*, for installation instructions.

After you have installed your software, perform the following steps:

1. Check your DAQ device jumper settings.
2. Configure your DAQ device.
3. Configure your SCXI system.

Refer to the Measurement & Automation Explorer online help for instructions on configuring your software.

Example Programs

You can learn more about the SCXI system by running the example programs that are included with all National Instruments application software packages and with the NI-DAQ software you received with your DAQ device. Be sure to read the information in the remarks at the top of each example program and configure your SCXI system appropriately. Refer to the NI-DAQ software documentation for detailed information about how each of the function calls works.

Connecting and Using Accessories and Transducers

This chapter describes the use of SCXI terminal blocks and connector-and-shell assemblies and explains how to connect three commonly used transducers—thermocouples, strain gauges, and resistive temperature detectors (RTDs)—to your SCXI system.

Connecting Signal Wires to the SCXI System

There are two methods for connecting signals to the SCXI system—using SCXI terminal blocks and using TBX terminal blocks. Because the front panel connectors of different SCXI modules have different pinouts, there are specific terminal blocks and connector-and-shell assemblies you can use with particular modules. You can use some terminal blocks with more than one module, as shown in Table 4-1.

Table 4-1. SCXI Module and Connector Compatibility

Module	Terminal/ Connector	Features		
		Cold-Junction Sensor	Isothermal	Others
SCXI-1100 SCXI-1102/B/C	SCXI-1300 SCXI-1303 TBX-1303	Yes Yes Yes	No Yes Yes	— Signal referencing and open thermocouple detection Current input Low-cost connector and shell
	SCXI-1308 SCXI-1310	No No	No No	
SCXI-1104/C	SCXI-1300, TBX-96	Yes No	Yes No	— —

Table 4-1. SCXI Module and Connector Compatibility (Continued)

Module	Terminal/ Connector	Features		
		Cold-Junction Sensor	Isothermal	Others
SCXI-1120/D SCXI-1125	SCXI-1320	Yes	No	
	SCXI-1327	Yes	No	100:1 attenuation of voltages to 250 V _{rms}
	SCXI-1328	Yes	Yes	—
	TBX-1328	Yes	Yes	—
	SCXI-1330	No	No	Low-cost connector and shell
	SCXI-1338	No	No	Current input
SCXI-1121	SCXI-1320	Yes	No	—
	SCXI-1321	Yes	No	Offset-nulling and shunt calibration for strain gauges
	SCXI-1330	No	No	Low-cost connector and shell Current input
SCXI-1122	SCXI-1322	Yes	No	—
SCXI-1124	SCXI-1325 TBX-1325	No	No	—
SCXI-1126	SCXI-1305	No	No	AC/DC coupling
	SCXI-1320	No	No	—
	SCXI-1327	Yes	No	100:1 attenuation of voltages to 250 V _{rms}
	SCXI-1330	No	No	Low-cost connector and shell
	SCXI-1338	No	No	Current input
	TBX-1329	No	No	AC/DC coupling

Table 4-1. SCXI Module and Connector Compatibility (Continued)

Module	Terminal/ Connector	Features		
		Cold-Junction Sensor	Isothermal	Others
SCXI-1140	SCXI-1301	No	No	Used with SCXI-1140 only
SCXI-1141	SCXI-1304	No	No	AC/DC coupling
SCXI-1142	SCXI-1305	No	No	AC/DC coupling
SCXI-1143	SCXI-1310	No	No	Low-cost connector and shell
SCXI-1160	SCXI-1324	No	No	—
SCXI-1161	—	No	No	—
SCXI-1162	SCXI-1326	No	No	—
SCXI-1162HV	TBX-1326	No	No	—
SCXI-1163				—
SCXI-1163R				—
SCXI-1180	SCXI-1302	No	No	—
SCXI-1181	SCXI-1301	No	No	—
	SCXI-1310	No	No	—
	SCXI-1330 ¹	No	No	—
SCXI-1200 ²	SCXI-1302	No	No	—
SCXI-1520	SCXI-1314	Yes	No	Quarter-bridge completion, shunt calibration resistors
SCXI-1530	—	No	No	—
SCXI-1531				
SCXI-1540	SCXI-1315	No	No	—
All modules	TBX-24F ³	No	No	—

¹ The SCXI-1330 connector is keyed for use with high-voltage modules. To use the SCXI-1330 with the SCXI-1181, you must remove the keys by sliding the two coding wedges from their dovetail grooves. The SCXI-1181 is not intended for use with hazardous voltages (exceeding 42 V_{rms}). National Instruments is not liable for damages or injuries resulting from improper installation.

² To connect signals to the SCXI-1200, you can also use a CB-50, a CB-50LP, a BNC-2081, or an SC-2071.

³ The TBX-24F is a general-purpose feedthrough connector that mounts on a DIN rail.

SCXI-13XX Terminal Blocks

An SCXI-13XX terminal block contains a number of labeled screw terminals to which you can connect signal wires, along with a strain-relief mechanism to prevent the connections from being inadvertently loosened. The terminal block fastens directly to the front of the appropriate SCXI module.

TBX Terminal Blocks

TBX terminal blocks provide DIN-rail mounted terminal blocks that you cable to the front of your SCXI modules. Figure 4-1 shows a TBX cabled to an SCXI module. Table 4-2 summarizes the TBX terminal blocks and the SCXI modules for which they were designed. The TBX terminal blocks are designed to mount on a DIN rail in a separate panel and provide easy access to the screw terminals. These terminal blocks are functionally equivalent to the SCXI-13XX terminal block counterparts.

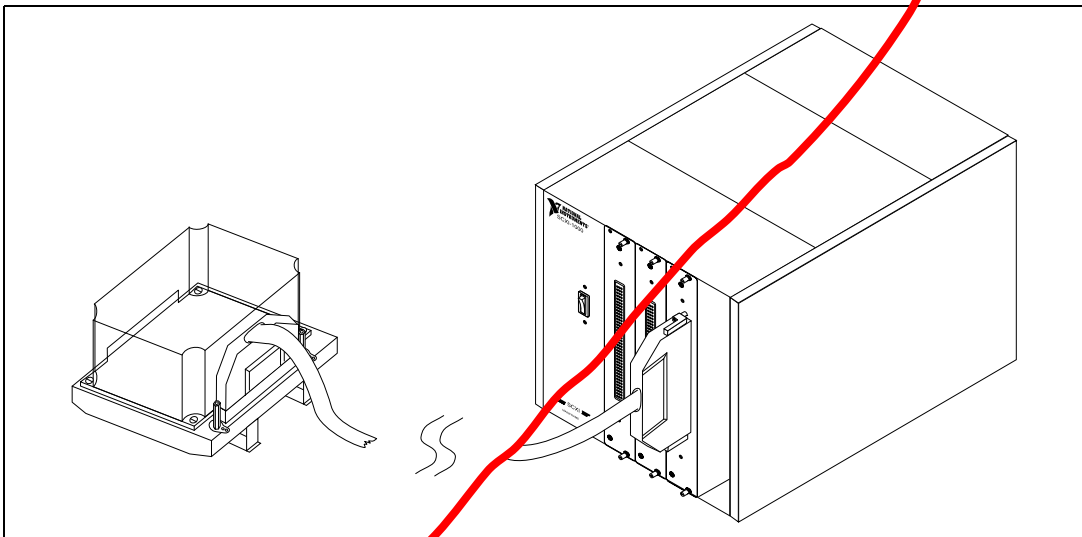

Figure 4-1. TBX Terminal Block Cabled to an SCXI Module

Table 4-2. TBX Terminal Block Compatibility with SCXI Modules

SCXI Module	TBX Terminal Block	Cable Assembly
SCXI-1100/1102	TBX-1303	SH96-96 or R96-96
SCXI-1124	TBX-1325	SH48-48A
SCXI-1162/1162HV/1163/1163R	TBX-1326	SH28-28B
SCXI-1120/1121/1125	TBX-1328	SH32-32A
All other SCXI modules	TBX-24F	—

Onboard Temperature Sensors for Cold-Junction Compensation

The SCXI-1300, SCXI-1303, TBX-1303, SCXI-1320, SCXI-1321, SCXI-1322, SCXI-1327, SCXI-1328, and TBX-1328 terminal blocks have onboard temperature sensors for measuring ambient temperature inside the terminal block. If you are measuring temperatures with thermocouples, you can obtain a temperature from the onboard temperature sensor that you can use for cold-junction compensation.

The voltage output from the onboard temperature sensor is multiplexed, along with other signals from the SCXI module, to channel 0 on the DAQ device. Read the temperature signal using the `SCXI_Single_Chan_Setup` call in NI-DAQ and specifying **Channel (-1)** in software, or by using the LabVIEW channel string `MTEMP`.

To scale the voltage reading from an SCXI-1300, SCXI-1320, or SCXI-1321 to temperature, multiply the value by 100 to get a temperature reading in degrees Celsius.

The SCXI-1303, TBX-1303, SCXI-1322, SCXI-1327, SCXI-1328, and TBX-1328 use a thermistor to measure the temperature. To convert the voltage reading to a temperature, use a thermistor conversion formula. In LabVIEW, use the Convert Thermistor VI. In NI-DAQ, use the `Thermistor_Convert` function call. Refer to *Transducer Conversion Functions* in the *NI-DAQ User Manual for PC Compatibles*, for more information.

Opening the SCXI-13XX Terminal Block

You open terminal blocks the same way that you open modules. Figure 4-2 shows the back of the terminal block.

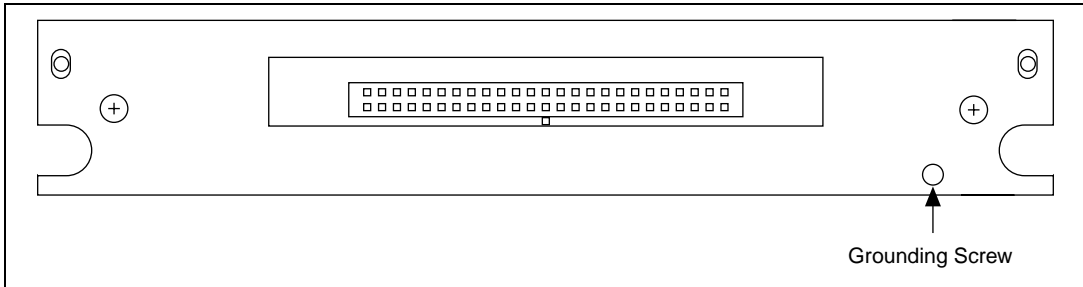

Figure 4-2. Removing the Terminal Block Grounding Screw

To open the terminal block, remove two cover screws as shown in Figure 4-3.

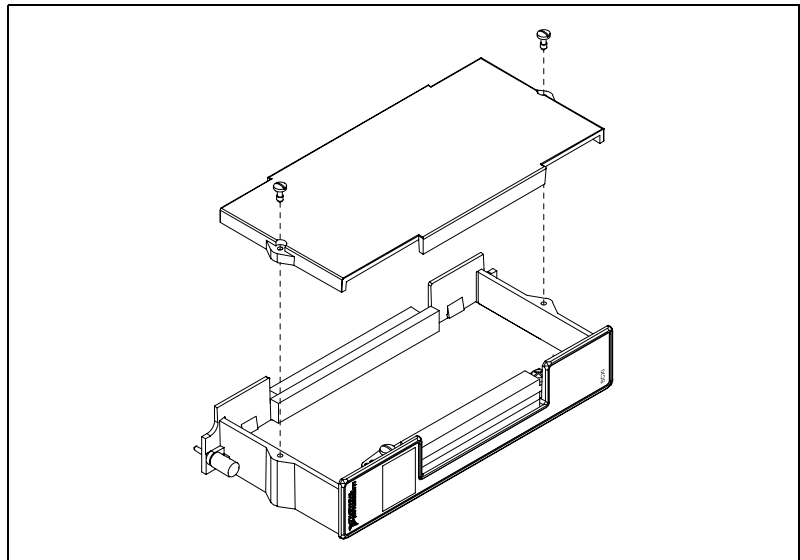

Figure 4-3. Removing the Terminal Block Cover

To replace the cover plate, align the cover at the top of the terminal block and replace the two screws.

Connector-and-Shell Assemblies

Connector-and-shell assemblies, which are low-cost alternatives to terminal blocks, have solder pins instead of screw terminals for more permanent configurations. Connector-and-shell assemblies do not have strain relief and are made of plastic instead of aluminum. The connector-and-shell assemblies include the SCXI-1310 and SCXI-1330. Table 4-1, earlier in this chapter, summarizes the module compatibility for these connectors.

Connecting Transducers to the SCXI System

National Instruments application software packages include transducer conversion functions for thermocouples, strain gauges, and RTDs. The following sections explain how to connect these transducers to the SCXI system.

Thermocouples

Thermocouples are among the most commonly used transducers. You can use the SCXI-1100 or the SCXI-1102 to condition up to 32 thermocouple signals. If you require isolation, you can use the SCXI-1120, the SCXI-1121, the SCXI-1122, or the SCXI-1125.

Using Thermocouples with the SCXI-1100

If the thermocouple is insulated or not ground-referenced, the thermocouple produces a floating signal. Therefore, you must ground-reference the thermocouple. You may acquire inaccurate readings if you do not use one of the following methods to ground the thermocouple.



Caution To avoid noise and errors from ground loops, do not reference the thermocouple to ground at more than one point.

The most convenient way to ground-reference your floating thermocouples is to use the SCXI-1303, the terminal block which provides a ground-reference for all 32 input channels. However, if you are using the SCXI-1300 terminal block, you must connect the negative lead of all your floating thermocouples to the negative terminal of the input channel and to chassis ground.

You can also ground the thermocouple at the source, assuming the ground difference between the source and your SCXI system is within the common-mode voltage range of the SCXI module. If the thermocouple is already ground-referenced, do not connect the negative input to chassis ground.



Note The SCXI-1100 has a jumper, W1, that connects a 100 k Ω resistor to ground at the output of the input multiplexer when measuring floating sources. However, when you are using thermocouples, leave jumper W1 in the factory-default position (no connect) because connecting jumper W1 introduces noise and settling time delays.

Using Thermocouples with the SCXI-1102

The most convenient way to ground-reference your floating thermocouples is to use the SCXI-1303 or TBX-1303, which provides a ground-reference for all 32 input channels. If you are using the SCXI-1303 or TBX-1303, install the supplementary 10 M Ω resistor networks into the terminal blocks. This configuration allows you to connect either floating or ground-referenced thermocouples to the SCXI-1102. However, if you are using the SCXI-1300, you must connect the negative lead of all your floating thermocouples to the negative terminal of the input channel and to chassis ground.



Note Chassis ground is also available at the strain-relief bar. Be certain to connect to chassis ground at only one point.

Using Thermocouples with the SCXI-1112, SCXI-1120, SCXI-1121, SCXI-1122, and SCXI-1125

The SCXI-1120, SCXI-1121, SCXI-1122, and SCXI-1125 modules have isolated analog inputs. Therefore, you can connect these modules directly to both floating and ground-referenced thermocouples. You do not need to reference a floating thermocouple to chassis ground. Simply wire the positive and negative lead of the thermocouple to the positive and negative terminals of the input channel on the terminal block.

Noise and Filtering

Because thermocouples inevitably pick up electrical noise, National Instruments recommends that you sample thermocouples at a higher rate than you actually need and average the data to reduce its noise variation. Try averaging at least 30 samples per reading. In addition, averaging over one power cycle helps reject power line noise; for example, averaging 100 samples per reading at a 6 kHz scan rate rejects 60 Hz noise in your SCXI system.

Hardware filtering is another way to reduce noise. The SCXI-1102, SCXI-1120, SCXI-1121, and SCXI-1125 have lowpass noise filters on every input channel that you can apply as detailed in Chapter 2, *Installing SCXI Modules and Connecting the SCXI System to the DAQ Device*. These filters are commonly used in thermocouple applications.

The SCXI-1100 includes a single selectable filter following the multiplexer. Therefore, enabling the 4 Hz filter limits sampling rates to less than 4 S/s—attempting to sample faster produces erroneous data. This is not a problem on the SCXI-1102, SCXI-1120, SCXI-1121, and SCXI-1125 because each channel has its own filter. Refer to Table 4-4 for SCXI-1100 maximum recommended sampling rates.

Strain Gauges

The strain gauge is another common transducer. The strain gauge requires excitation; therefore, an SCXI-1121 or **SCXI-1122 module** is suitable for measuring this transducer.

First, establish whether the strain gauge is a quarter-bridge, half-bridge, or full-bridge configuration and determine the level and type of excitation the strain gauge requires.

For example, a half-bridge configuration commonly requires a voltage excitation of 3.333 V. Because the strain gauge requires 3.333 V of excitation, you do not need to change the settings of the excitation mode or level jumpers because 3.333 V is the factory-default setting. Because you have a half-bridge strain gauge configuration, you must enable the half-bridge completion network. Set jumpers W17 and W18 (for channel 1) to the positions shown in Table 3-15.



Warning If the strain gauge has a high common-mode voltage, refer to Appendix A, *Specifications*, of the *SCXI-1121 User Manual* to verify that the common-mode voltage is within the specified limits before connecting the signal to the SCXI-1121.

Failure to verify that the common-mode voltage is within specified limits can damage the SCXI system and is potentially dangerous. National Instruments is *not* liable for damages or injuries resulting from improper configuration. If you have a large common-mode voltage ($\geq 30 V_{\text{rms}}$ and $42.4 V_{\text{peak}}$ or 60 VDC), ground the terminal block to safety earth ground as shown in Figure 4-4.

Connect the strain gauge to the SCXI-1321 terminal block as shown in Figure 4-4. You can also use the SCXI-1320 for this arrangement.

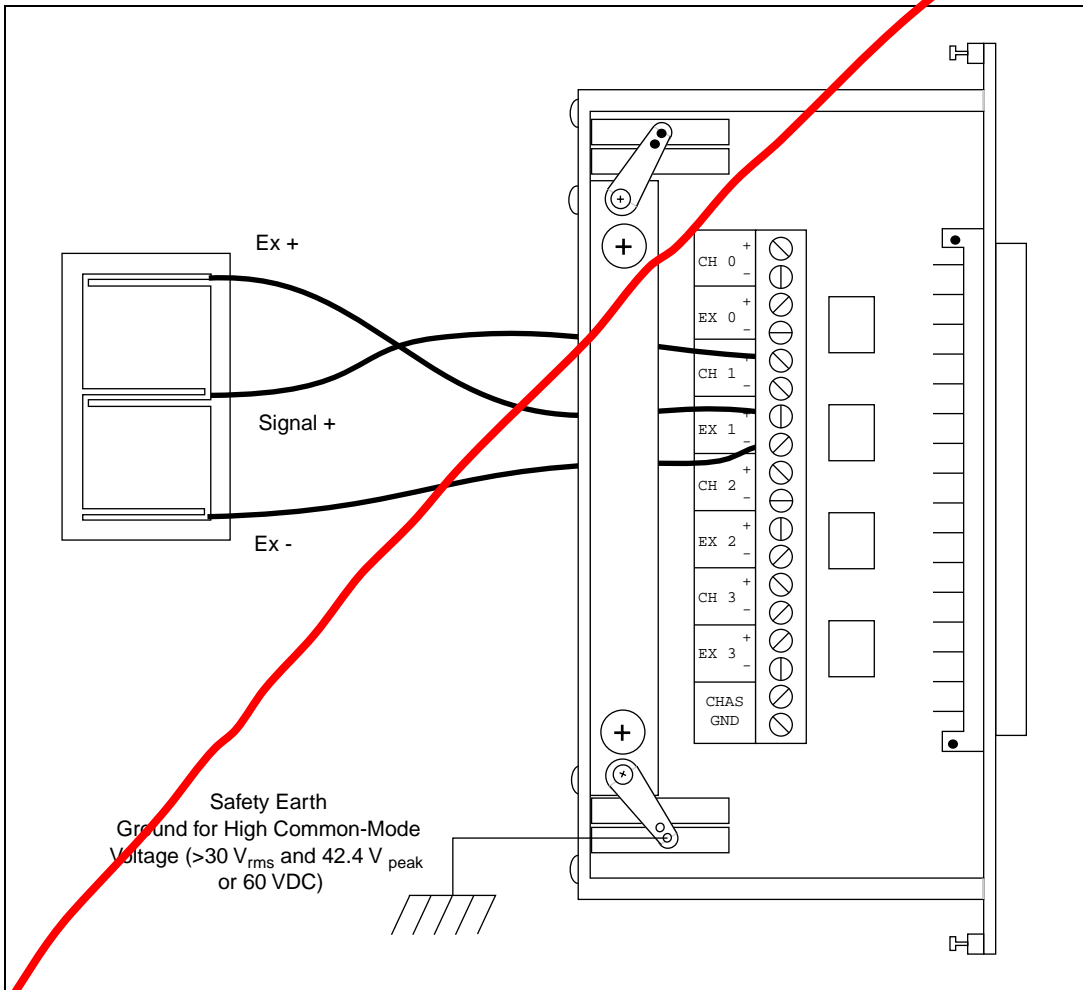

Figure 4-4. Connecting the Half-Bridge Strain Gauge to Channel 1 of the SCXI-1321 Terminal Block

If your strain gauge is a quarter-bridge configuration, you still need to enable the bridge-completion network, but you must also install a dummy resistor with resistance equal to that of the strain gauge at no load. If you have a full-bridge configuration, you do not need to enable the bridge-completion network. In all configurations, however, you must still use excitation. Figures 4-5, 4-6, and 4-7 show a number of possible bridge configurations in which V_{EX} , R_1 , and R_2 are on the SCXI 1121 module. To determine which of the following bridge configurations your strain gauge uses, refer to your strain gauge manufacturer manual.



Note The following acronyms and symbols apply to Figures 4-5 through 4-7:

- ε = strain
- GF = Gauge Factor
- ν = Poisson's Ratio
- $V_r = [(V_{IN}/V_{EX})_{Strained} - (V_{IN}/V_{EX})_{Unstrained}]$
- R_L = Line Resistance
- R_g = Gauge Resistance
- = Connection to Terminal Block

Quarter-Bridge Configuration I

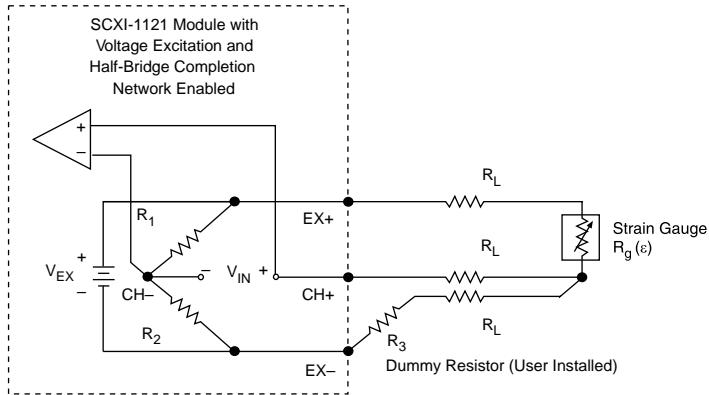

Note: National Instruments recommends that you select R_3 equal to $R_g(\epsilon)$ at no load.

$$\text{strain}(\epsilon) = \frac{-4 V_f}{GF(1 + 2V_f)} \cdot \left(1 + \frac{R_L}{R_g} \right)$$

Quarter-Bridge Configuration II

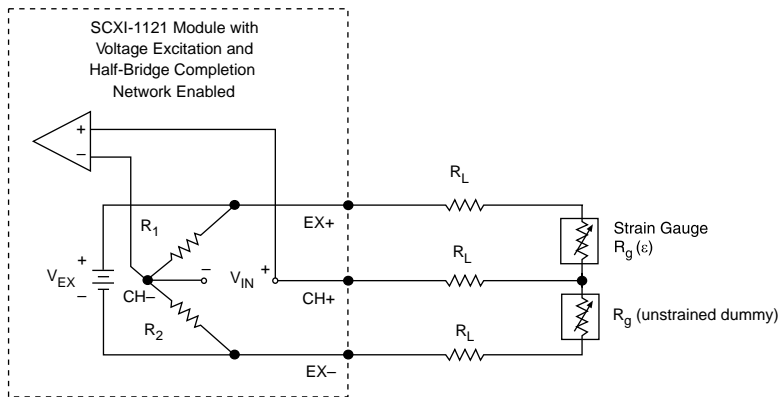

$$\text{strain}(\epsilon) = \frac{-4 V_f}{GF(1 + 2V_f)} \cdot \left(1 + \frac{R_L}{R_g} \right)$$

Figure 4-5. Quarter-Bridge Configurations

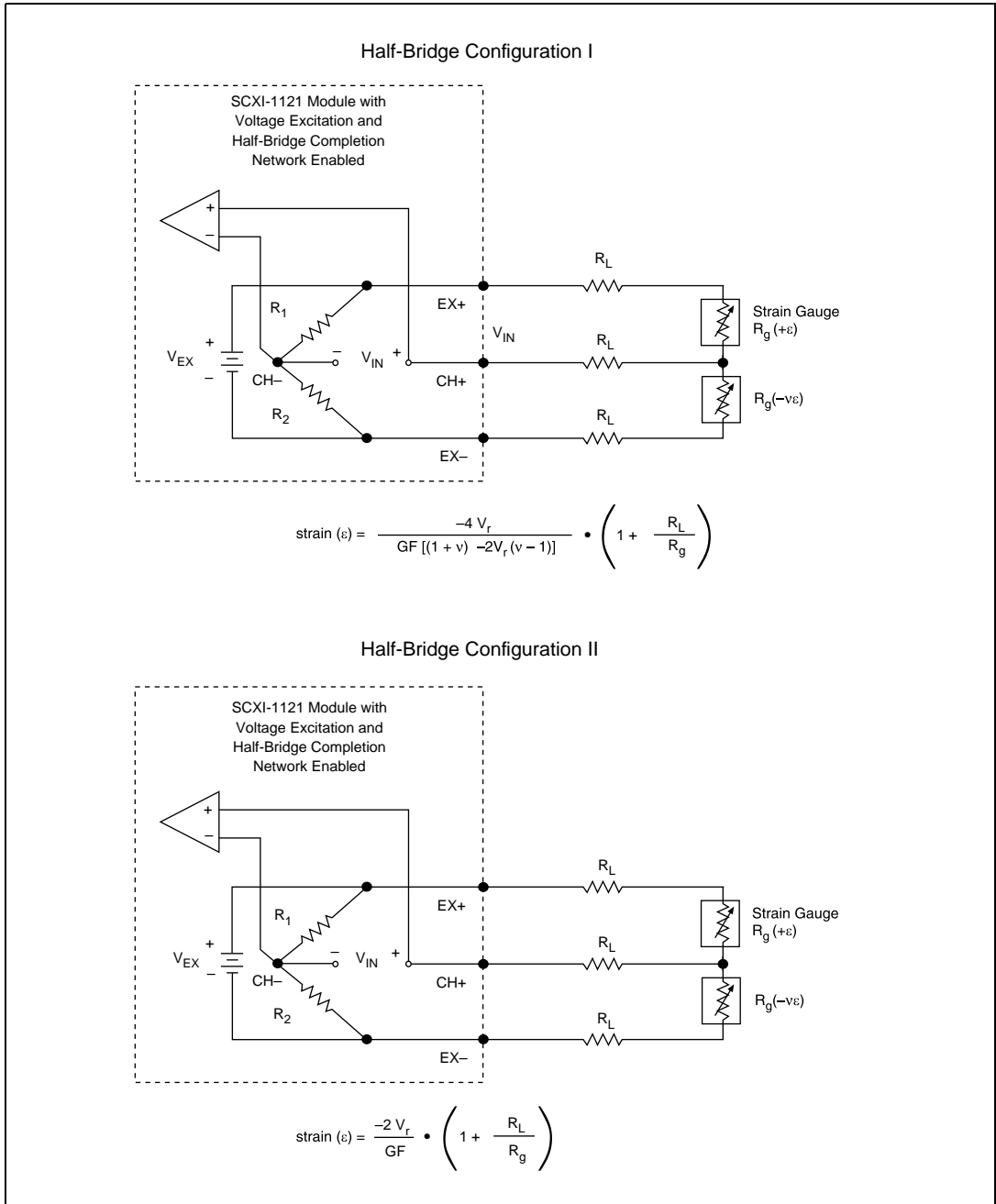

Figure 4-6. Half-Bridge Configurations

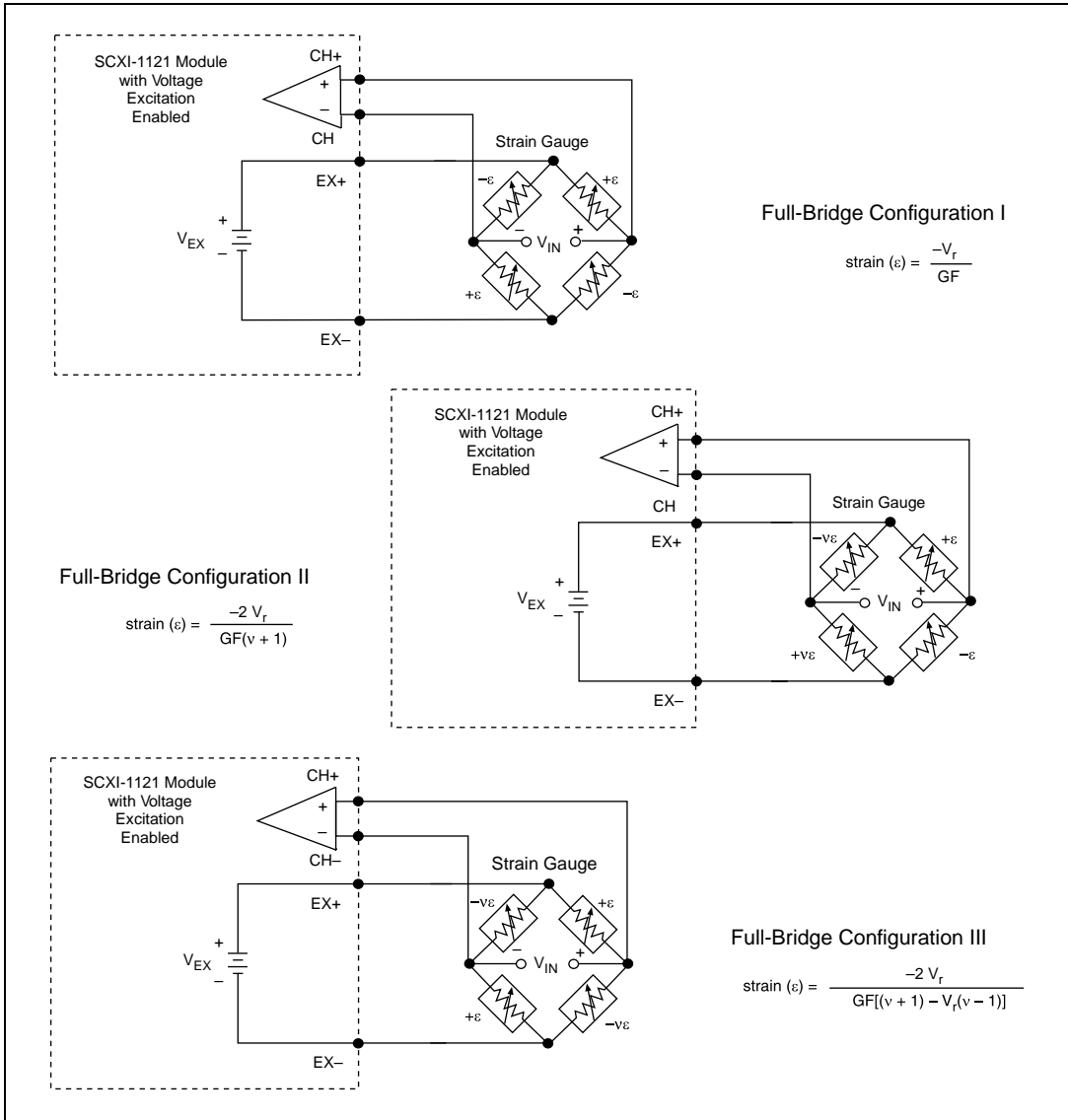

Figure 4-7. Full-Bridge Configurations

Using Strain Gauges with the SCXI-1520

The SCXI-1520 allows you to set the voltage excitation level over the range 0 to 10 V at 0.625 V resolution. To prevent the module from overheating, the voltage should not be set greater than

$$(total\ load\ resistance\ per\ channel) \times (28.6\ mA)$$

Table 4-3 shows maximum allowable excitation voltages for standard bridge configurations and gauge resistances.

Table 4-3. Excitation Voltage Ranges for Configuration and Gauge Resistances

Configuration/Sensor	Resistance	Excitation Voltage Range
Quarter or Half Bridge	120 Ω	0 to 6.250 V
	350 Ω	0 to 10 V
	1000 Ω	0 to 10 V
Full Bridge or Full-Bridge Sensor	120 Ω	0 to 3.125 V
	350 Ω	0 to 10 V
	1000 Ω	0 to 10 V

Figures 4-8, 4-9, and 4-10 show examples of quarter-bridge, half-bridge, and full-bridge strain gauge connections, respectively, to the SCXI-1520 through the accessory SCXI-1314 terminal block. The quarter-bridge completion resistor and shunt calibration resistors are in sockets. You can change the quarter-bridge completion resistor to match the resistance of your strain gauge without resoldering. Half-bridge completion is provided inside the SCXI-1520 module. You configure the module for half-bridge completion under software control.

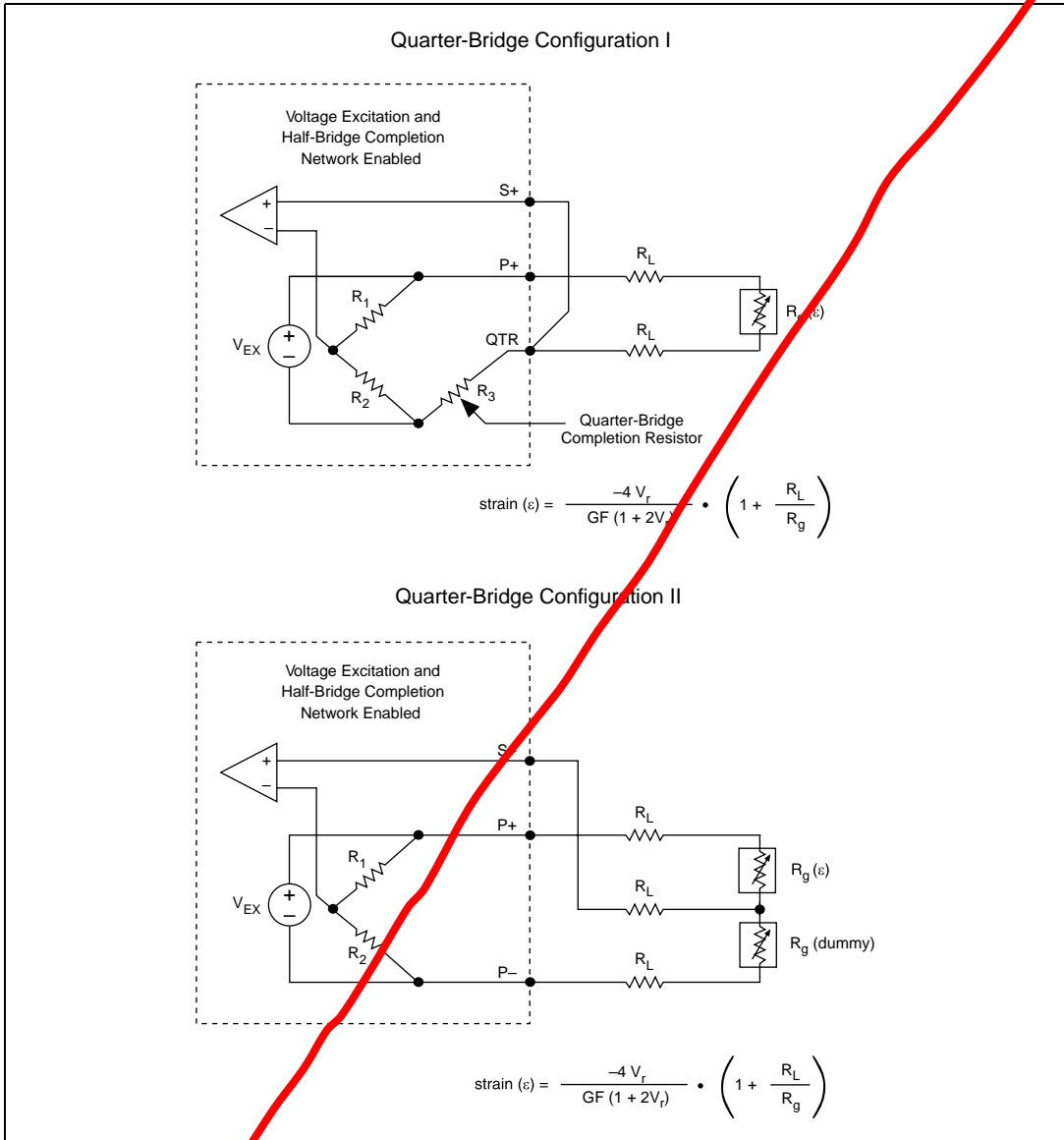

Figure 4-8. SCXI-1520 to SCXI-1314 Quarter-Bridge Connection

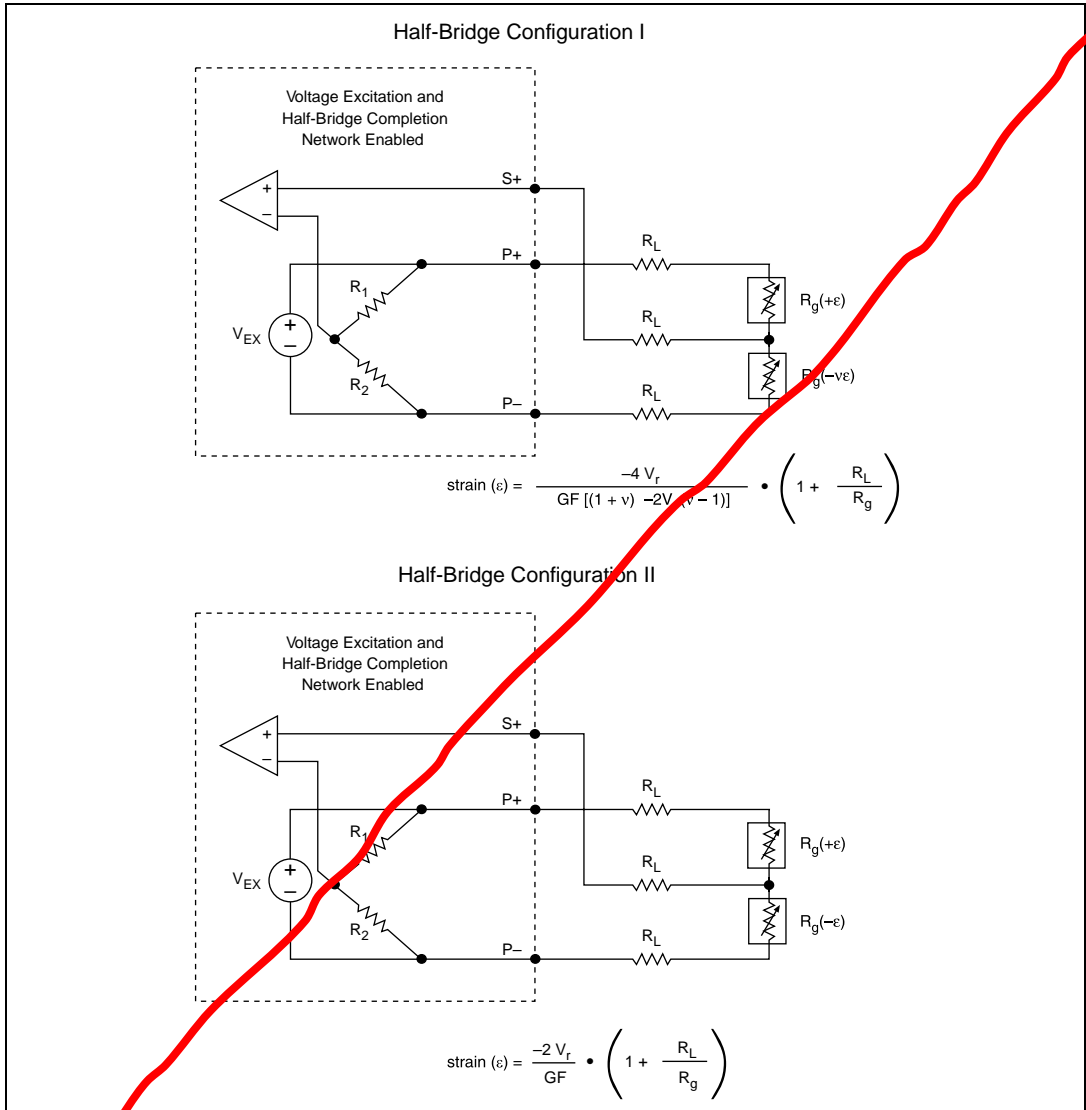

Figure 4-9. SCXI-1520 to SCXI-1314 Half-Bridge Connection

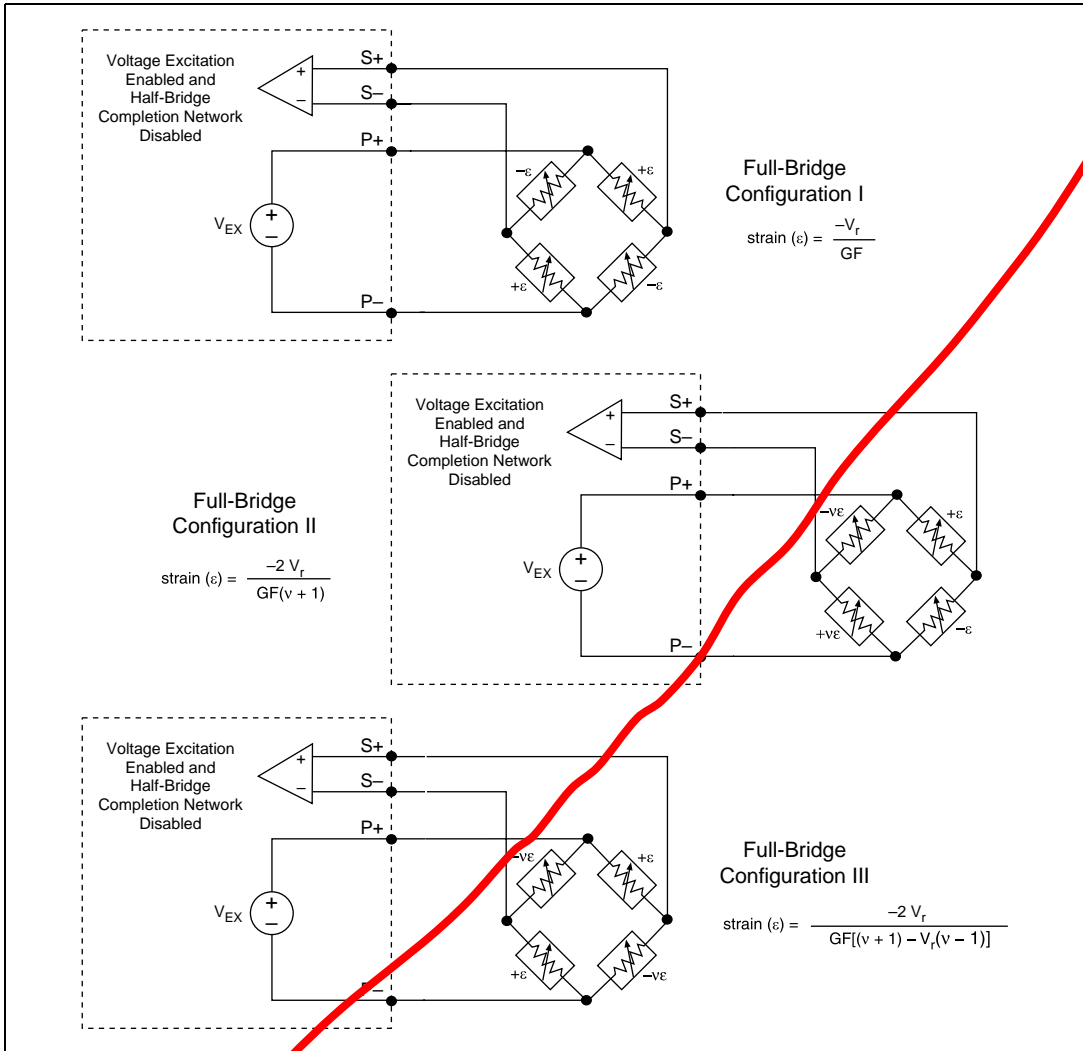

Figure 4-10. SCXI-1520 to SCXI-1314 Full-Bridge Connection

RTDs

An RTD requires excitation, thus, the SCXI-1121 module is a suitable choice for conditioning the signal. Determine your RTD type and configuration. The RTD in this example is a 100 Ω , four-wire platinum RTD, which is common. In general, the RTD uses current excitation. However, you can use RTDs in a Wheatstone bridge configuration with voltage excitation. Refer to your RTD specification literature to determine the level of current or voltage excitation the RTD requires.

Follow these steps to connect the RTD to channel 1 of the SCXI-1320 terminal block:

1. Set jumpers W22 and W23 to select current excitation, as shown in Table 3-12.
2. Set jumpers W24 and W25 to configure the excitation current level to either 0.150 mA or 0.450 mA, as shown in Table 3-13.



Note You do not need to enable the half-bridge completion network.

3. Connect the RTD to channel 1 of the SCXI-1320 terminal block, as shown in Figure 4-11.



Warning Before you connect the RTD to the SCXI-1121, verify that the common-mode voltage is within limits. Refer to Appendix A, *Specifications*, in the *SCXI-1121 User Manual*. Common-mode voltage that is not within the specified limits can damage the SCXI system and is potentially dangerous. National Instruments is not liable for damages or injuries from improper configuration. If you have a common-mode voltage greater than or equal to 42 V_{rms}, ground the terminal block to safety earth ground as shown in Figure 4-11.

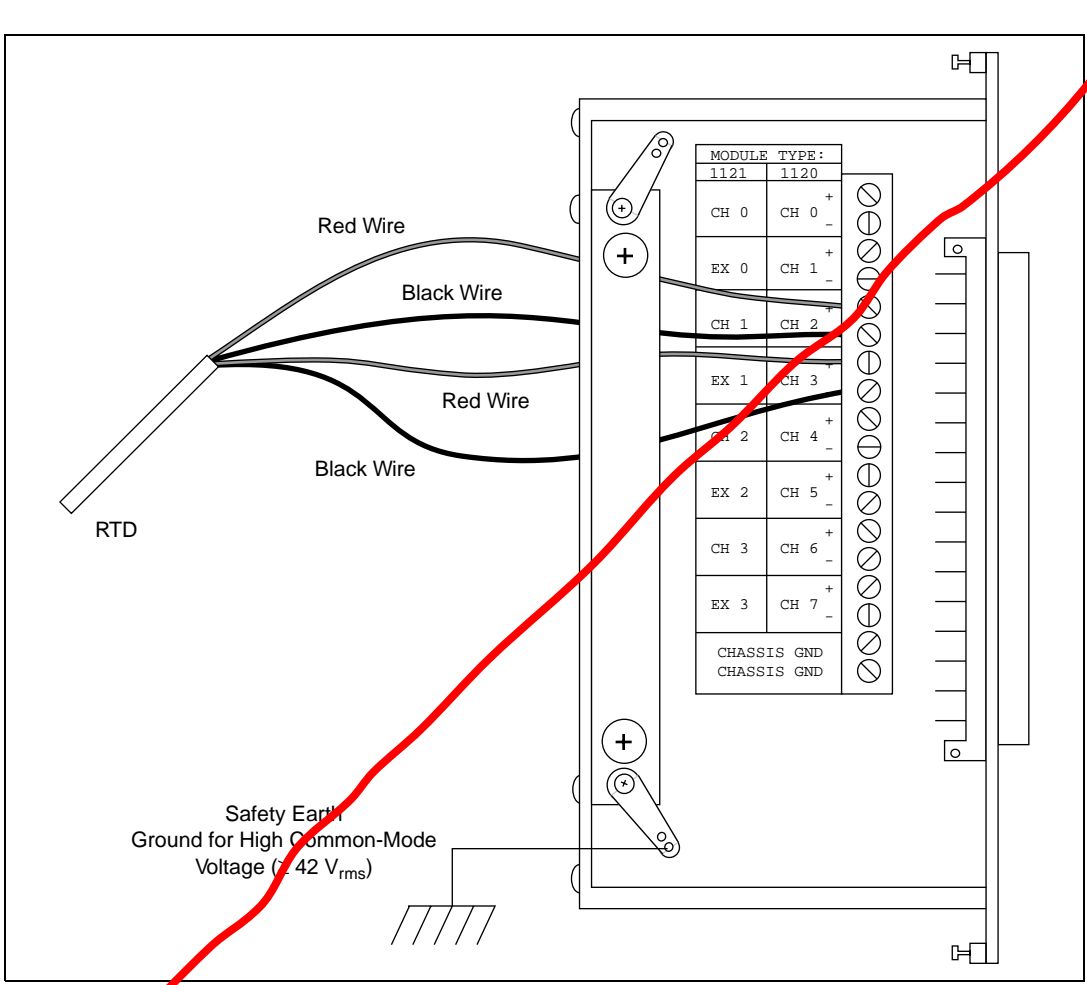

Figure 4-11. Connecting a Four-Wire Platinum RTD to Channel 1 of the SCXI-1320

Figure 4-12 shows how to connect commonly configured RTDs to the SCXI-1121 module.

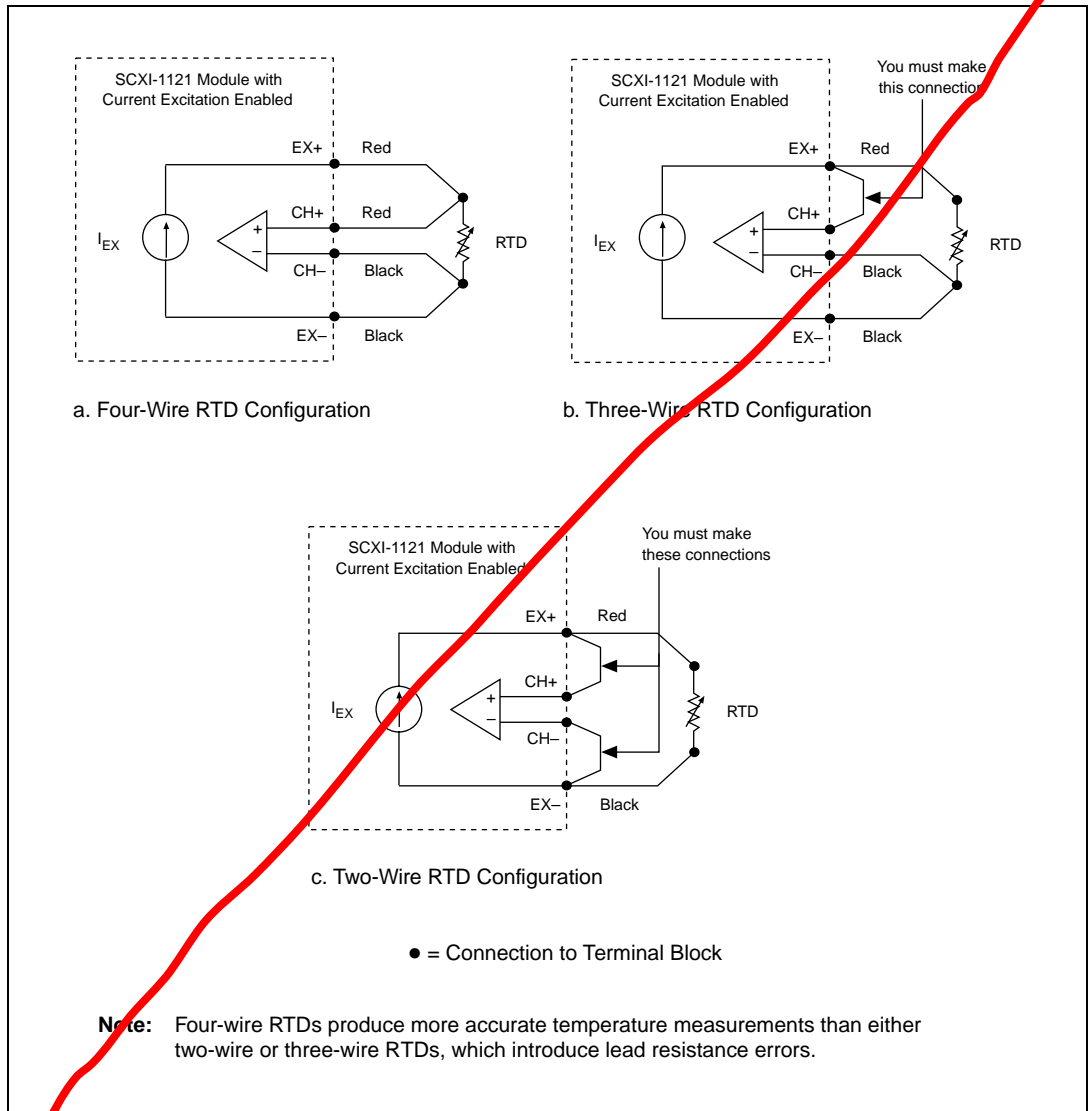

Figure 4-12. SCXI-1121 RTD Configurations

Excitation Channel Signal Connections on the SCXI-1122

The SCXI-1122 has a voltage (**VEX**) and a current excitation (**IEX**) channel, which are available at the front connector. In addition, **VEX/2** is available for half-bridge and quarter-bridge transducers. Both channels are isolated from earth ground up to 450 V_{rms} working common-mode voltage. Notice that the voltage and current excitation channels are electrically isolated from each other but do not provide a *safety isolation* between them.



Warning Exceeding the overvoltage protection or isolation rating on the excitation output can damage the SCXI-1122, the SCXIbus, and the DAQ device. National Instruments is not liable for any damages or injuries resulting from such signal connections.

Excitation Level

Each excitation channel of the SCXI-1122 has one level:

- Current excitation—1 mA
- Voltage excitation—3.333 V

It is important that you do not exceed the maximum permissible load of each channel as listed in Table 4-4.

Table 4-4. SCXI-1122 Maximum Load per Excitation Channel

Excitation Level	Maximum Load
3.333 V	225 mA
1 mA	5 kΩ

Using Internal Half-Bridge Completion

Your SCXI-1122 includes half-bridge completion for half-bridge and quarter-bridge setups. The completion network consists of two $2.5\text{ k}\Omega \pm 0.02\%$ ratio tolerance resistors with a temperature coefficient of $2\text{ ppm}/^\circ\text{C}$. These resistors are connected in series. To use the network, connect the VEX/2 screw terminal on the terminal block to the negative input of the channel of interest, as shown in Figure 4-13.

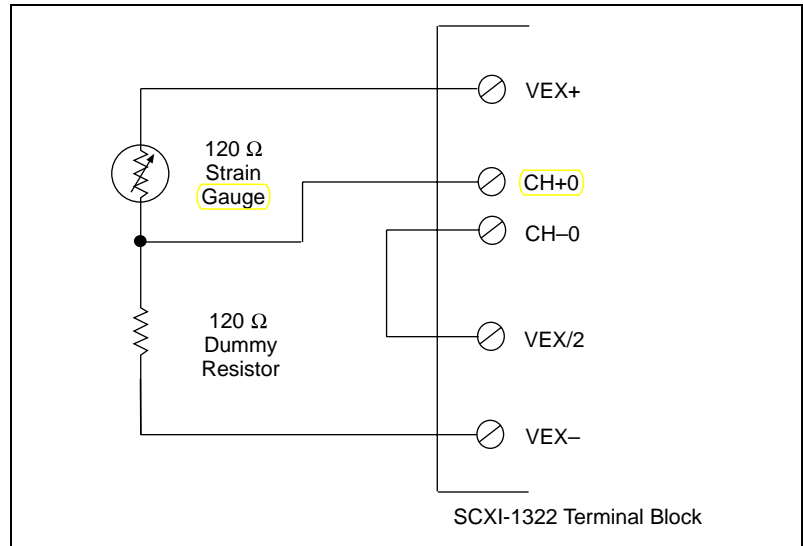

Figure 4-13. Connecting a Quarter-Bridge Strain Gauge to Channel 0



Note When using the half-bridge completion network with a quarter-bridge configuration, you must use an extra resistor to complete the bridge. Place this resistor on the terminal block between the positive input channel and the negative excitation output.

Analog Circuitry in the SCXI-1122

The analog circuitry consists of a relay multiplexer, a software-programmable gain isolation amplifier, software-programmable filtering, a temperature sensor channel for cold-junction compensation, calibration circuitry, and voltage and current excitation channel outputs.

Analog Input Channels

A relay multiplexer routes input signals to the isolation amplifier. This relay multiplexer can be configured in two-wire or four-wire mode scanning. In the two-wire scan mode, all 16 channels operate as voltage sense channels. At any time only one of 16 channels is connected to the isolation amplifier. In the four-wire scan mode, the 16 channels are divided into two banks that switch synchronously. The eight upper channels (0 through 7) operate as voltage sense channels and one out of eight is connected to the amplifier at any time. In addition, the eight lower channels (8 through 15) operate as current output channels that switch in tandem with the sense channels. At any time only one channel is connected to the current excitation channel. Table 4-5 lists the sense and current output channel associations.

Table 4-5. Sense and Current Output Channel Associations

Sense	Current Output
Channel 0	Channel 8
Channel 1	Channel 9
Channel 2	Channel 10
Channel 3	Channel 11
Channel 4	Channel 12
Channel 5	Channel 13
Channel 6	Channel 14
Channel 7	Channel 15

The temperature sensor consists of a thermistor located on the SCXI-1322 terminal block. This thermistor connects through the temperature channel to the isolation amplifier. The temperature sensor is for cold-junction compensation of thermocouples. When measuring the temperature sensor output, set your SCXI-1122 for a gain of 5 and a 4 Hz filter. This increases the measurement resolution and accuracy and reduces noise.



Note With a 4 Hz bandwidth, you must wait 1 s before you take the temperature measurement to permit the system to settle. If you want to use the 4 kHz filter, take a large number of samples and average them. To reject 50 or 60 Hz noise, you should acquire multiple samples over an integral number of power-line cycles, then average these samples.

The filtering consists of one of two lowpass filters, 4 kHz (–3 dB) or 4 Hz (–10 dB), which you can select through software control. These cascaded filters are located in two stages to help eliminate noise introduced by the isolation amplifier.

The isolation amplifier fulfills two purposes on the SCXI-1122 module. The isolation amplifier converts a small signal riding on a high common-mode voltage into a single-ended signal with respect to the SCXI chassis ground. With this conversion, you can extract the input analog signal from a high common-mode voltage or noise before it is sampled and digitized by the DAQ device. The isolation amplifier also amplifies the input signal, which increases measurement resolution and accuracy. The isolation amplifier drives the analog output stage, which contains circuitry that permits several module output signals to multiplex into one DAQ device channel.

The calibration hardware consists of a software-controlled shunt calibration resistor for strain gauge calibration, an autozeroing calibration for nulling the amplifier offsets, and an EEPROM that holds calibration constants for software correction of gain and offset of the isolation amplifier and of the current and voltage excitation channels.

Excitation Output Channels

In addition to the isolated input channels, the SCXI-1122 has two isolated excitation output channels, one 3.333 V voltage output source and one 1 mA current output source. Both channels—like the input channels—have 450 V_{rms} common-mode voltage with respect to earth ground and 250 V_{rms} common-mode voltage between each other and any other channel. Both channels are overvoltage-protected to 250 V_{rms} and are current-limited.

The voltage excitation channel is for transducers, such as strain gauges, which need voltage excitation to operate properly. The maximum current that this channel can provide is 225 mA. Exceeding this limit will cause the channel to lose regulation. This channel has four terminals, two sense terminals (SENSE+ and SENSE–), and two excitation terminals (VEX+ and VEX–), which you can use for remote load regulation. For proper operation, the SENSE+ terminal must always be connected to the VEX+, and the SENSE– terminal to the VEX–. Refer to the *SCXI-1322 Terminal Block Installation Guide* for further details on using the sense terminals for remote load sensing.

The voltage excitation channel is primarily used to provide power to a strain gauge configured in a Wheatstone bridge. To verify correct bridge operation, you can use shunt calibration.

When you select shunt calibration during a Wheatstone bridge strain measurement, a 301 k Ω , 1% resistor internally shunts across the strain gauge between the VEX+ and the CH+ terminals. This resistor is socketed so you can change its value to meet your requirements. To permit the system to settle, when you are either enabling or disabling the shunt calibration resistor, you must wait 1 s if you have selected 4 Hz bandwidth or wait 10 ms if you have selected 4 kHz bandwidth. Finally, to determine the effect of the shunt resistor on your measurement, use the following procedure.

Assuming a quarter-bridge strain-gauge configuration with a gauge factor of GF = 2, the equivalent strain change the R_{SCAL} shunting resistor introduces is -199 $\mu\epsilon$. This is determined as follows:

1. Determine the change the shunt resistor causes using the following formula:

$$V_{change} = \frac{V_{EX}R(R_{SCAL} + R_g)}{R_gR_{SCAL} + R(R_{SCAL} + R_g)} - \frac{V_{EX}}{2}$$

where

V_{EX} is the excitation voltage.

R_{SCAL} is the shunting resistor.

R_g is the nominal strain-gauge resistance value.

2. Using the appropriate strain-gauge formula and assuming that you have no static voltage, determine the equivalent strain that the R_{SCAL} resistor should produce. For example, if your SCXI system is configured with R_{SCAL} = 301 k Ω , a quarter-bridge 120 Ω strain gauge with a gauge factor of GF = 2, VEX = 3.333 V, and R = 120 Ω , the following result occurs:

$$V_{change} = 0.3321 \text{ mV}$$

Replacing the strained voltage with V_{change} in the quarter-bridge strain equation produces an equivalent -199 $\mu\epsilon$ of change.

The current output channel is for transducers, such as thermistors and RTDs, that need current excitation to operate properly. The current output has a value of 1 mA and has a maximum permissible load of 5 k Ω . If you connect loads greater than 5 k Ω , the current source will lose regulation. When connecting several loads that need current excitation, you have two alternatives. The first approach is to connect them all in series (as long as they do not exceed 5 k Ω total) and use the two-wire scan mode as shown in

Figure 4-14. The second approach is to use the four-wire scan mode and connect them as shown in Figure 4-15.

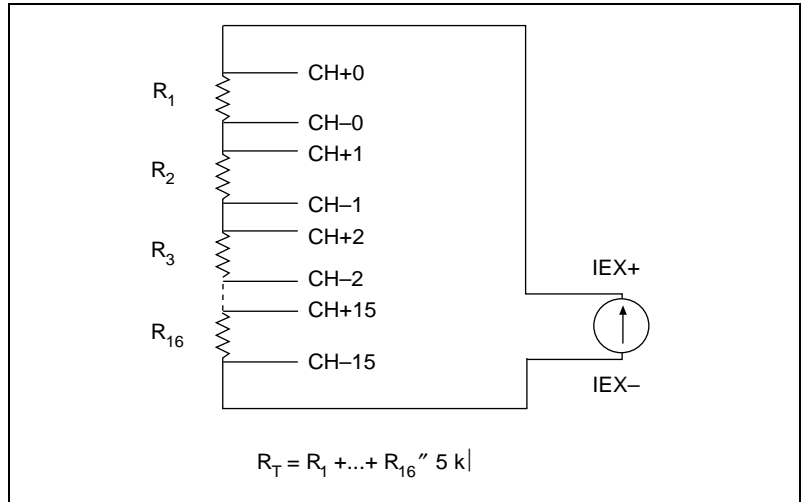

Figure 4-14. Series Connection with Current Excitation

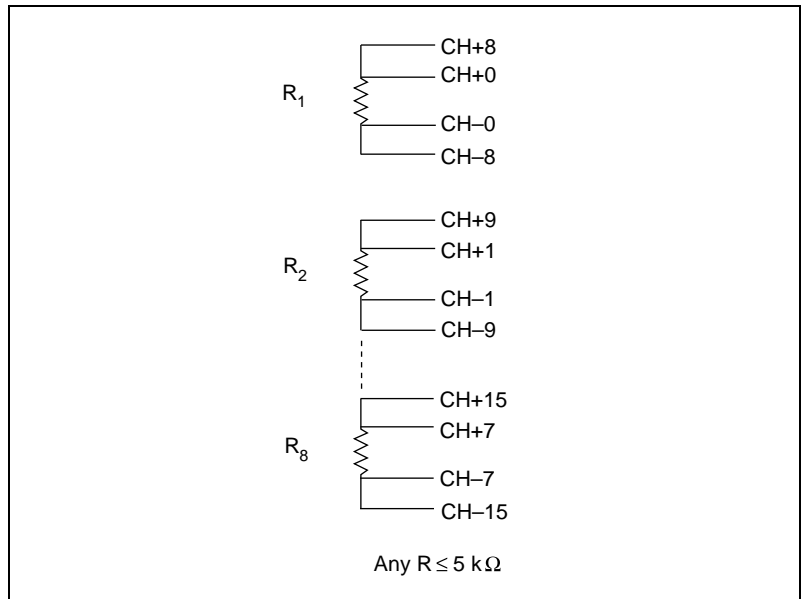

Figure 4-15. Four-Wire Scan Connection with Multiplexed Current Excitation



Note Always connect the current excitation terminals outside the sense terminals as shown in both Figures 4-14 and 4-15.

Each approach has its advantages and disadvantages, as listed in Table 4-6.

Table 4-6. Pros and Cons of Two-Wire and Four-Wire Connections with Current-Excited Transducers

Type	Pros	Cons
Series connection with two-wire scanning	<p>16 transducers per module</p> <p>All transducers are continuously excited</p> <p>Two-wire connections are easier to connect because of fewer wires</p>	<p>Limited to 5 kΩ total resistance</p> <p>No isolation between channels</p>
Independent connection with four-wire scanning	<p>5 kΩ per channel</p> <p>250 V_{rms} common-mode voltage (CMV) isolation between transducers</p>	<p>Eight transducers maximum per module</p> <p>More connections</p>

Analog Output Channel Signal Connections on the SCXI-1124

You can connect each SCXI-1124 output channel independently for voltage output or current output. Each channel is referenced to its own isolated ground. Each isolated ground can have up to 250 V_{rms} of CMV between itself and any other channel ground or chassis ground. The following illustrations show how to make different types of signal connections. The dots in the figures indicate where you connect wires to the SCXI-1325 terminal block. For information on how to connect the wires to your terminal block, consult the *SCXI-1325 High-Voltage Terminal Block Installation Guide*.

Figure 4-16 shows how to connect a DAC channel as a voltage output.

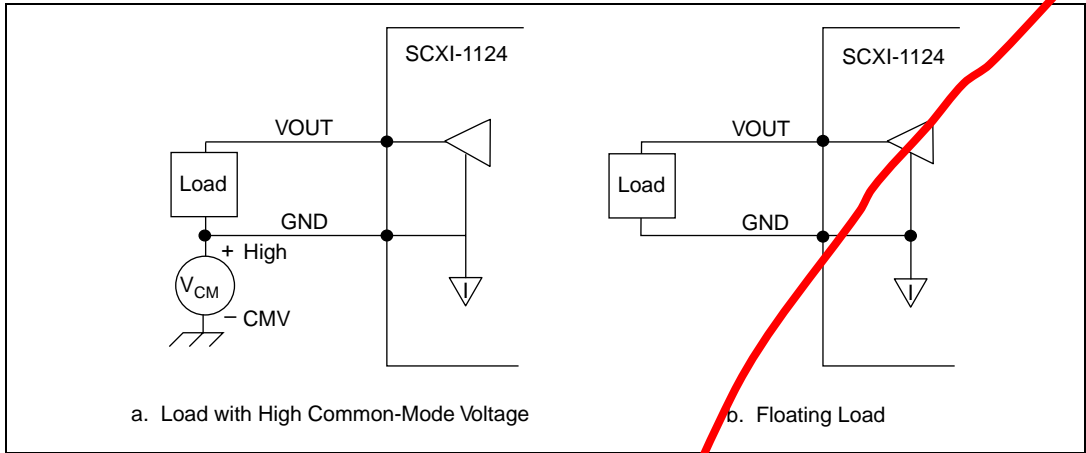

Figure 4-16. DAC Channel Connection as Voltage Output

Figure 4-17 shows how to connect a DAC channel as a current output using the channel loop supply.

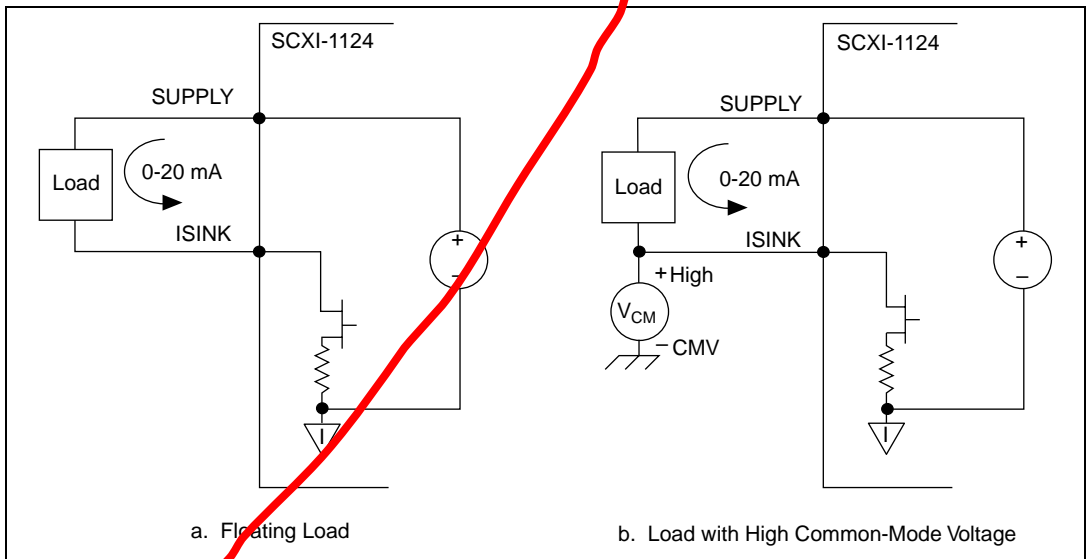

Figure 4-17. DAC Channel Connection as Current Output, Internal Loop Supply

Figure 4-18 shows how to connect a DAC channel as a current output using an external loop supply.

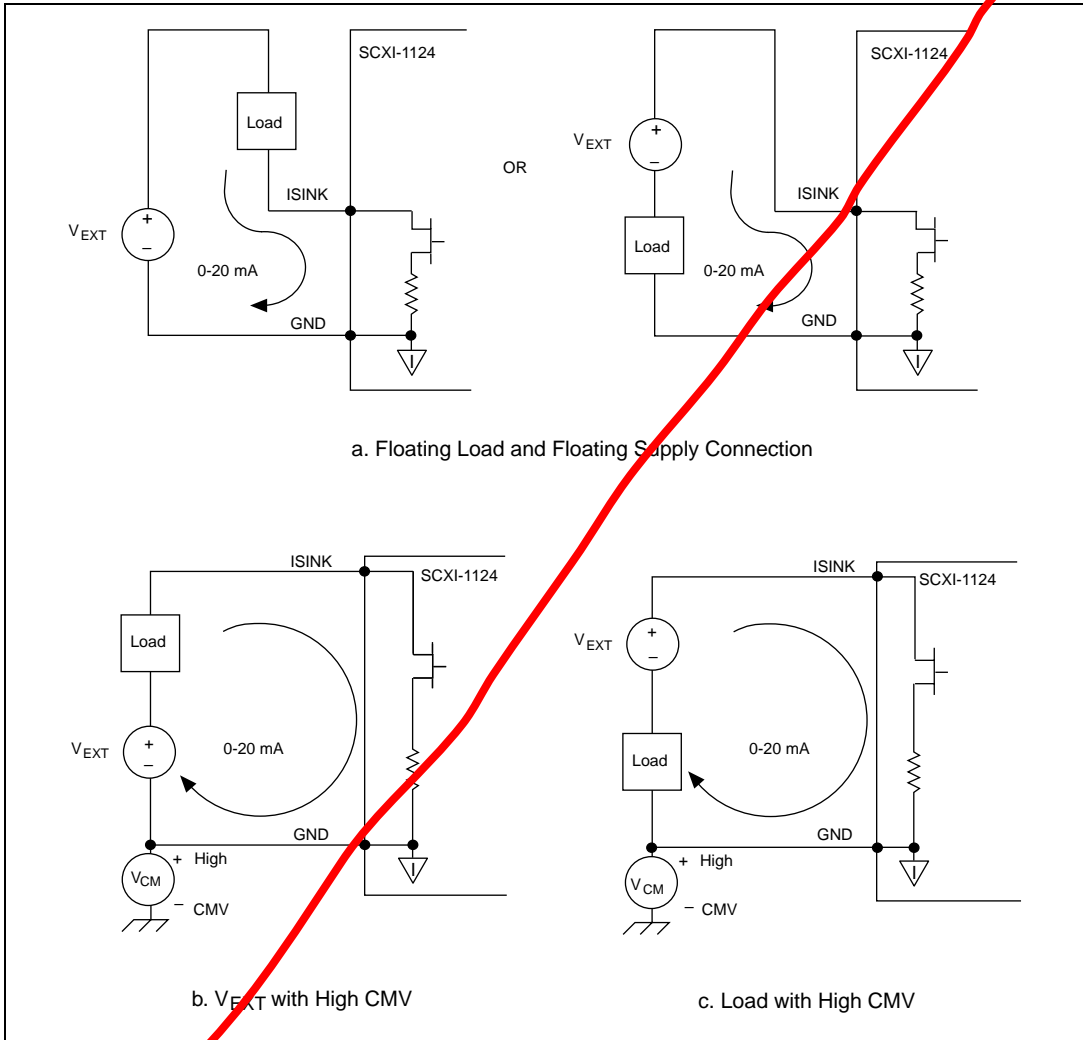

Figure 4-18. DAC Channel Connection as Current Output, External Loop Supply

When you use an external supply, the order of supply and load does not matter as long as you do not create a second loop through which current flows. If both your supply and load are grounded, you must connect your signals as shown in Figure 4-19a. The circuit in Figure 4-19b does not work.

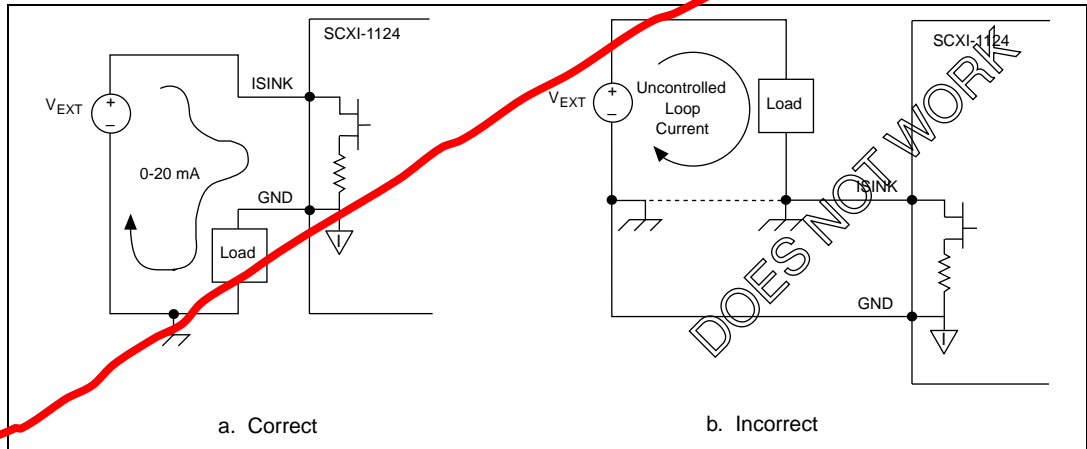

Figure 4-19. Current Loop Connection, Load and External Supply Both Grounded

Chassis Ground Connections

The front signal connector also has a chassis ground pin. If you have any floating channels (channels that are not already referenced to ground from your signal connections) that you want to reference to earth ground, connect the isolated ground of the channel to the chassis ground pin. Do *not* use this pin as a safety earth ground because the ground trace cannot handle the potentially large currents that result when the channel is short-circuited to high voltage. Use the strain-relief tab on the terminal block for the safety earth ground.

LVDTs, RVDTs, and Resolvers

LVDTs, RVDTs, and resolvers require signal conditioning with AC excitation and synchronous demodulation. The SCXI-1540 provides these specialized functions.

Connecting to LVDTs and RVDTs

Figures 4-20 and 4-21 show the connections made to a 4-wire and 5-wire LVDT or RVDT using the SCXI-1540 with the SCXI-1315 terminal block. Figure 4-20 shows that you can connect a device with six wires using only four wires. In general, the 5-wire connection is insensitive to phase shift in the transducer and wiring, but subject to interference from common-mode voltages in the cable such as AC hum picked up from power lines. It is therefore advisable to use the 4-wire connection except in cases where a large phase shift in the return signal is suspected. Causes for a large phase shift might be the use of an operating frequency other than that specified by the sensor manufacturer or a cable run >100 m.

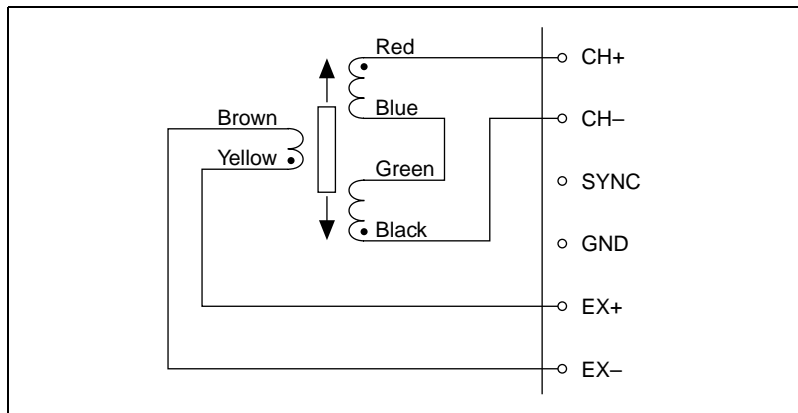

Figure 4-20. 4-Wire Connection

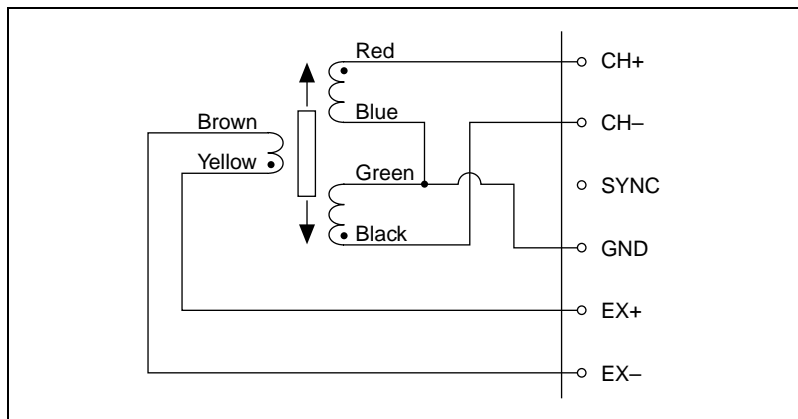

Figure 4-21. 5-Wire Connection



Note The default configuration setting for the SCXI-1540 is 4-wire. You must use Measurement & Automation Explorer or the NI-DAQ function `SCXI_Configure_Connection` to enable 5-wire operation in addition to making the correct signal connections in the terminal block or front signal connector.

Synchronizing Channels

Figure 4-22 shows how to synchronize multiple SCXI-1540 channels to the same frequency. Do this for all channels that share a common cable. Synchronization prevents beat frequencies from appearing in the data. Beat frequencies are the result of channel oscillators running at slightly different frequencies and coupling into adjacent channels through crosstalk in the cable.

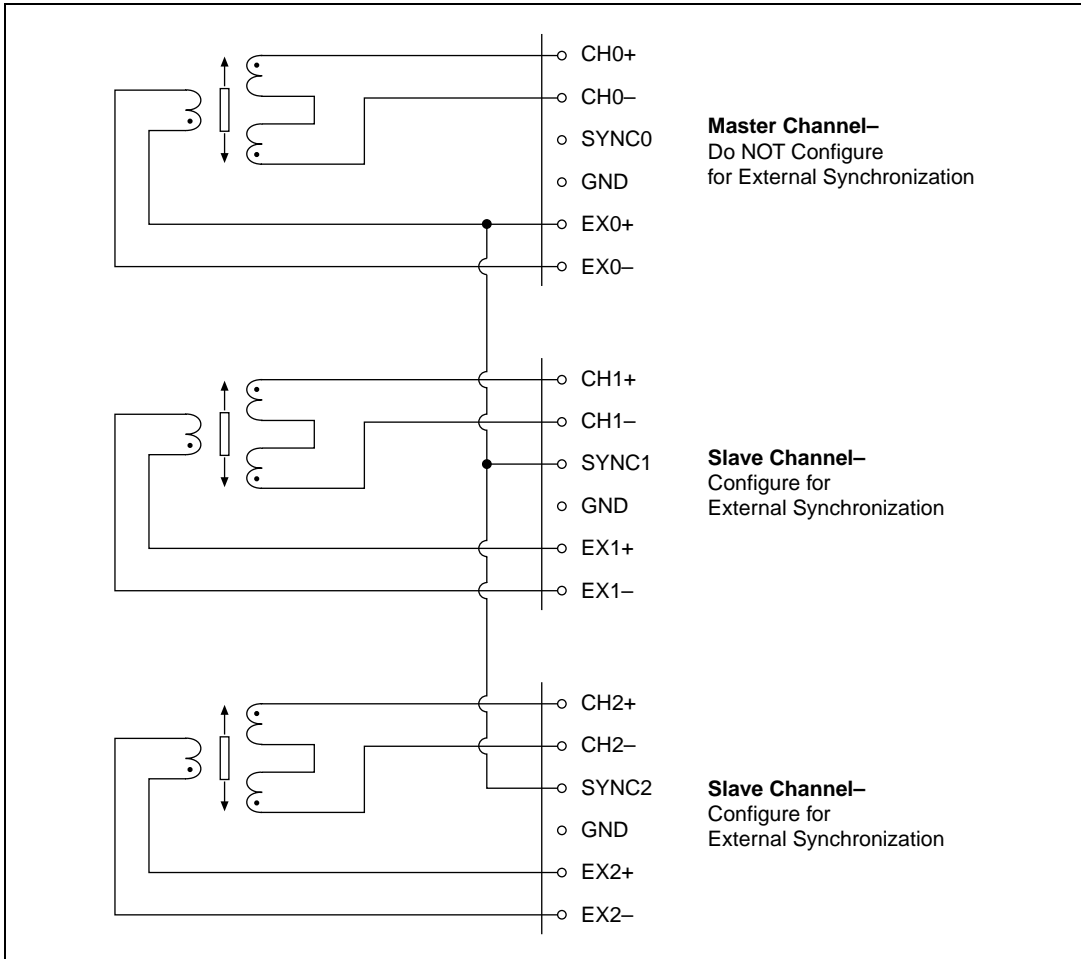

Figure 4-22. Synchronizing Multiple Channels



Note To synchronize multiple channels, you must make the connections shown in Figure 4-22 and configure the slaved channels for external synchronization. This is done through Measurement & Automation Explorer or by using the NI-DAQ function `SCXI_Configure_Connection`. You must *not* configure for external synchronization the channel that originates the synchronization signal from its EX+ pin, channel 0 in the example of Figure 4-22, since it serves as master and is not slaved to any other channel.

Connecting to Resolvers

Figure 4-23 shows the connections made between a resolver and the SCXI-1540 using the SCXI-1315 terminal block. A single resolver requires the use of two channels. You must synchronize both channels using a wire connection between EX+ on the master channel and SYNC on the slave channel. Configure the slave channel for external synchronization as described in the previous note. You can also synchronize more than two channels used for resolvers or combinations of resolvers, LVDTs, and RVDTs by the method described in [Synchronizing Channels](#).

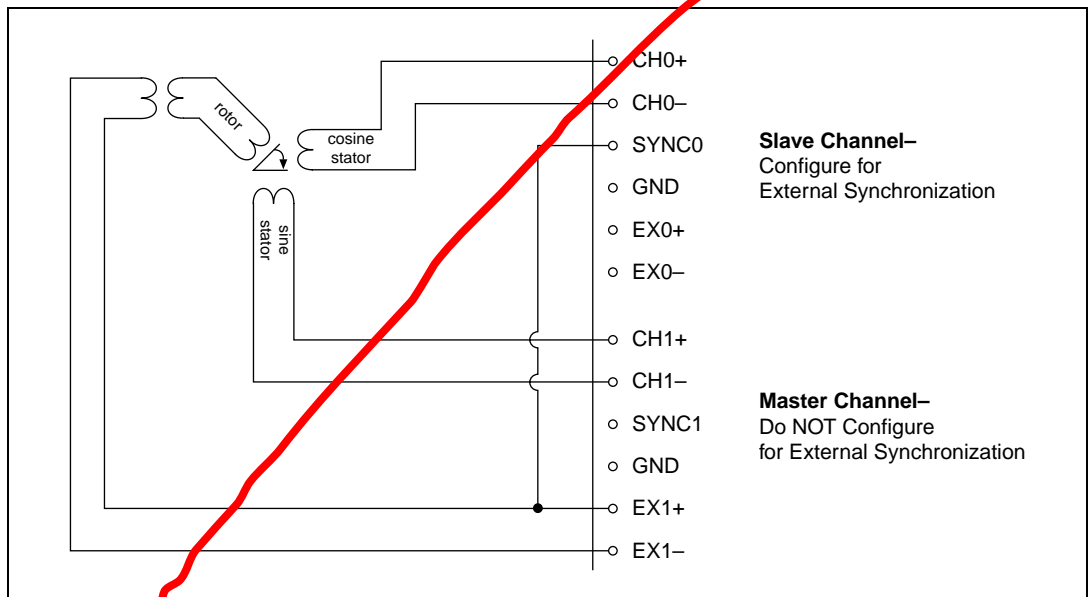

Figure 4-23. Interfacing to a Resolver

SCXI Troubleshooting and Common Questions

This appendix contains troubleshooting tips and answers to questions that SCXI users commonly ask National Instruments technical support staff. Before you contact National Instruments, try the following troubleshooting tips.

Troubleshooting Tips

- Make sure you have the most recent version of the NI-DAQ driver software.
- Can Measurement & Automation Explorer establish communication with the chassis? If not, try one or all of the following:
 - Connect the DAQ device to a different module in the chassis.
 - Try a different cable assembly.
 - Try a different chassis.
 - Try a different DAQ device.
- If you have multiple chassis, disconnect them and reconnect them one at a time to isolate the problem.
- Make sure that each SCXI chassis connected to a single DAQ device has a unique address.
- If you have multiple SCXI modules, remove all the modules and test each module individually.
- If a particular chassis does not work, try another one.
- If you are getting erroneous readings from your signal source, disconnect the signal source and short the input channel to ground. You should get a 0 V reading.
- Alternately, connect a battery or other known signal source to the input channel.
- Run an example program to see if you still get erroneous results.

Common Questions and Problems

All my channels float to a positive rail when I try to take a measurement.

Make sure that the signal reference settings for your DAQ device match the SCXI module. For example, if your device is configured for NRSE, make sure that the cabled SCXI module is also (this may require a jumper setting).

I am trying to communicate with multiple chassis over an RS-485 network but can communicate only with the first chassis or not at all.

To communicate with multiple chassis, the communication path from the computer to the SCXI chassis must also be RS-485, using either an installed RS-485 communications card or an RS-232/RS-485 converter. Each chassis must have a unique HDLC address. Make sure the RS-485 network is configured for 4-wire operation. You must also be using NI-DAQ for PC compatibles version 4.9.0 or later.

When using LabVIEW, how do I address the SCXI-1200 analog input channels?

Use the onboard channel number to address a particular analog input channel. Do not use the SCXI string `ob0!sc1!md...`.

Using LabVIEW, I am acquiring two ground-referenced signals with my SCXI-1100. I am using the string `1!MD1!0:1`; the channel 0 signal comes from a 2 V source and the channel 1 signal originates from a 5 V source. My scan rate is 10 Hz, which is relatively slow. My software reading for channel 0 is about the same as channel 1. What is wrong?

If you have enabled the 4 Hz or 10 kHz filter on the SCXI-1100, or if you are using high gains, set the interchannel delay to a value that gives the amplifier time to settle for each channel. The default interchannel delay is automatically set to the shortest interval with which the DAQ device can work, but no faster than 3 μ s if you are using SCXI. You can use the AI Config VI to specify a longer interchannel delay, or you can use the advanced Analog Input Clock Config VI to specify slower channel clock parameters. Do not confuse the scan rate parameter, which determines the time between successive scans, with the channel rate. You can specify the scan rate, but not the channel rate, for the Easy I/O VIs and most of the Data Acquisition example VIs.

My chassis worked fine until I inadvertently removed and reinserted a module while the chassis was on. Now my chassis does not turn on. What can I do?

You may have blown a fuse. Consult the *SCXI Chassis User Manual* for more information on your fuses.

I am using an SCXI-1100 module and SCXI-1300 terminal block with a thermocouple that measures room temperature. How do I stop the thermocouple reading from fluctuating erratically?

Most thermocouples are floating signal sources with low common-mode voltage; they require a path for bias currents from the SCXI-1100 amplifier to ground. Check jumper W1 on your SCXI-1100 module to make sure the jumper is in the factory-default position. Make sure that you have grounded the negative lead of each floating thermocouple and that your grounded thermocouples do not have high common-mode voltages. Average your temperature readings to minimize fluctuations that remain.

I understand my SCXI-1100 has software-programmable gain, but I need to continuously acquire data at different gains without stopping to change the gain on my SCXI module. How can I do this?

You can use any MIO device to accomplish this. Assume you need to set the gain for the first eight channels on the module to 100 and the gain for the last 24 channels to 1,000.

Set the SCXI module gain to the lowest required gain and create multiple entries in the MIO device scan list that use different MIO device gains so that the total gain on each channel will be the desired gain. For this example, set the SCXI module gain to 100, and set the MIO device gain to 1 for the first eight channels and 10 for the last 24 channels.

In NI-DAQ for PC compatibles and NI-DAQ for Macintosh, use the function call `SCXI_Set_Gain` to set the SCXI-1100 gain to 100. Then call the function `SCXI_MuxCtr_Setup (deviceNumber, 1, 1, 8)`; this specifies that eight SCXI module channels are scanned for each entry in the MIO device scan list. The MIO device channel list is `{0, 0, 0, 0}` (remember that in multiplexed mode only MIO device channel 0 is used), and the MIO device gain list is `{1, 10, 10, 10}`. The first eight channels on the module will have a total gain of $100 \cdot 1 = 100$, and the last 24 channels will have a total gain of $100 \cdot 10 = 1,000$. Notice that you are

now using four MIO device scan list entries instead of just one. For more complicated gain distributions, your MIO device scan list will be longer.

In LabVIEW, use the channel list strings and input limits arrays to specify your gain distribution. You do not need to set the SCXI-1100 gain in the configuration utility; the Analog Input VIs determine the best module gain and MIO device gains for you based on your input limits. Put two entries in the channel list array—OB0 ! SC1 ! MD1 ! 0:7, and OB0 ! SC1 ! MD1 ! 8:31. Put two entries in your input limits cluster array. Set the first element limits to $\{-0.1 \text{ to } 0.1\}$ and the second element limits to $\{-0.01 \text{ to } 0.01\}$. Using the OB0 specifier in your channel strings causes the Analog Input Hardware Config VI to modify the onboard MIO device gains as well as the SCXI module gain. The group channel settings array that the Analog Input Hardware Config VI returns shows the input limits and total gain for each channel, so you can verify your gain distribution. If your gain distribution results in an MIO device scan list that is too long for your MIO device, the Analog Input Hardware Config VI returns the -100370 error code (badScanListError).

I have four SCXI-1140 modules and one SCXI-1100. Which module should I connect to my DAQ device?

Connect one of the SCXI-1140 modules to your DAQ device to ensure that the track-and-hold signal from a counter on your DAQ device has a path to the SCXIbus. Other SCXI-1140 modules can obtain this signal from the backplane.

I have two SCXI-1100 modules and an SCXI-1340 cable assembly, which has three 50-pin connectors. I know I should connect one end of the cable assembly—the end with a single connector—to my DAQ device. The other end of the cable assembly has a female connector, which I plug into one of the modules, and a male connector. What do I do with that male connector?

Nothing, usually. The extra male connector on a cable assembly is called the breakout connector. You can use the breakout connector, in conjunction with the SCXI-1180, SCXI-1181, or SCXI-1351, to access unused DAQ device signals.

My SCXI-1162 module cannot read serial data unless I connect it directly to my DAQ device. Also, my SCXI-1163 module seems to be reading faulty information from the status registers. What is causing these problems?

The SCXI-1162 and SCXI-1163 send digital data to the SCXIbus. However, the analog modules, by default, do not send digital data from the SCXIbus to the DAQ device. If you have digital and analog SCXI modules in the same chassis and control them all through a DAQ device cabled to an analog module, you must configure that analog module to route digital data from the SCXIbus to the DAQ device.

Each SCXI module user manual explains how to configure the module, with two jumpers, to route data. One jumper connects the SCXIbus MISO line to SERDATOUT; the other jumper connects a pullup resistor to the MISO line.

What signals are reserved by SCXI on my plug-in device?

Table A-1 shows which signals SCXI reserves.

Table A-1. Onboard Resources Reserved by SCXI

SCXIbus Line	E Series MIO	SCXI-1200 Only	DIO-24	DIO-96	DIO-32HS
MOSI	DIO0	PB4	PB3	APB3	DIOB3
D*/A	DIO1	PB5	PB2	APB2	DIOB2
INTR*	DIO2	PB6	PB1	APB1	DIOB1
SPICLK	EXTSTROBE*	PB7	PB0	APB0	DIOB0
MISO	DIO4	PC1	PA0	APA0	DIOA0



Note SCXI also reserves a counter on your DAQ device for the Track/Hold signal.

Technical Support Resources

Web Support

National Instruments Web support is your first stop for help in solving installation, configuration, and application problems and questions. Online problem-solving and diagnostic resources include frequently asked questions, knowledge bases, product-specific troubleshooting wizards, manuals, drivers, software updates, and more. Web support is available through the Technical Support section of www.ni.com

NI Developer Zone

The NI Developer Zone at zone.ni.com is the essential resource for building measurement and automation systems. At the NI Developer Zone, you can easily access the latest example programs, system configurators, tutorials, technical news, as well as a community of developers ready to share their own techniques.

Customer Education

National Instruments provides a number of alternatives to satisfy your training needs, from self-paced tutorials, videos, and interactive CDs to instructor-led hands-on courses at locations around the world. Visit the Customer Education section of www.ni.com for online course schedules, syllabi, training centers, and class registration.

System Integration

If you have time constraints, limited in-house technical resources, or other dilemmas, you may prefer to employ consulting or system integration services. You can rely on the expertise available through our worldwide network of Alliance Program members. To find out more about our Alliance system integration solutions, visit the System Integration section of www.ni.com

Worldwide Support

National Instruments has offices located around the world to help address your support needs. You can access our branch office Web sites from the Worldwide Offices section of www.ni.com. Branch office web sites provide up-to-date contact information, support phone numbers, e-mail addresses, and current events.

If you have searched the technical support resources on our Web site and still cannot find the answers you need, contact your local office or National Instruments corporate. Phone numbers for our worldwide offices are listed at the front of this manual.

Glossary

Prefix	Meaning	Value
μ-	micro-	10^{-6}
m-	milli-	10^{-3}
k-	kilo-	10^3
M-	mega-	10^6

Numbers/Symbols

ε	strain
Ω	ohm
°	degree
%	percent
+	plus
-	minus
±	plus or minus
ν	Poisson ratio

A

A	amperes
AC	alternating current
accelerometer	a transducer that converts acceleration into a voltage or current
A/D	analog-to-digital
ADC	A/D converter. An electronic device, often an integrated circuit, that converts an analog voltage to a digital number.

ADC resolution the resolution of the ADC, which is measured in bits. An ADC with 16 bits has a higher resolution, and thus a higher degree of accuracy, than a 12-bit ADC

AI analog input

ANSI American National Standards Institute

AT E Series devices these AT devices have an *E*- toward the ends of their names, such as the AT-MIO-16DE-10 and AT-AI-16XE-10

B

bandwidth the range of frequencies present in a signal, or the range of frequencies to which a measuring device can respond

base address A memory address that serves as the starting address for programmable registers. All other addresses are located by adding to the base address.

beat frequencies A tone or frequency created by the mixing of two separate frequencies. The beat frequency is usually the difference between the two frequencies.

bipolar a signal range that includes both positive and negative values (for example, -5 V to +5 V)

bit one binary digit, either 0 or 1

bus The group of conductors that interconnect circuits in a computer. Typically, a bus is the expansion vehicle to which I/O or other devices are connected. Examples of PC buses are the AT bus, NuBus, Micro Channel, EISA bus, and PCI bus.

byte Eight related bits of data, an 8-bit binary number. Also used to denote the amount of memory required to store one byte of data.

C

C Celsius

CMOS complementary metal-oxide semiconductor

CMV common-mode voltage

cold-junction compensation	a method of compensating for thermoelectric voltages created when a thermocouple is connected to a measurement device
conversion time	The time required, in an analog input or output system, from the moment a channel is interrogated (such as with a read instruction) to the moment that accurate data is available.
counter/timer	a circuit that counts external pulses or clock pulses (timing)
coupling	the manner in which a signal is connected from one location to another
CPU	central processing unit
crosstalk	an unwanted signal on one channel due to an input on a different channel

D

D/A	digital-to-analog
DAC	D/A converter. An electronic device, often an integrated circuit, that converts a digital number into a corresponding analog voltage or current.
DAQ	Data acquisition. (1) Collecting and measuring electrical signals from sensors, transducers, and test probes or fixtures and inputting them to a computer for processing. (2) Collecting and measuring the same kinds of electrical signals with A/D and/or DIO devices plugged into a PC, and possibly generating control signals with D/A and/or DIO devices in the same PC.
DAQCard-500/700	refers to the DAQCard-500 and DAQCard-700
DAQCard E Series	refers to the DAQCard-AI-16E-4 and DAQCard-AI-16XE-50
DC	direct current
device	Device is used to refer to a DAQ device inside your computer or attached directly to your computer through a parallel port. Plug-in devices, PCMCIA cards, and devices such as the DAQPad-1200, which connects to your computer parallel port, are all examples of DAQ devices. SCXI modules are distinct from devices, with the exception of the SCXI-1200, which is a hybrid.

DIFF (differential) input	an analog input consisting of two terminals, both of which are isolated from computer ground, whose difference is measured
digital port	See port
DIO	digital I/O
DIO-24	refers to the PC-DIO-24, DAQCard-DIO-24, and PCI-6503
DIO-32	refers to the PCI-DIO-32HS, PCI-6533, or PXI-6533
DIO-96PnP	refers to the PC-DIO-96PnP
DIO device	refers to any digital I/O devices that have <i>DIO</i> in their names, such as the PC-DIO-96PnP
DIP	dual-inline package
DLL	Dynamic-link library. A software module in Microsoft Windows containing executable code and data that can be called or used by Windows applications or other DLLs. Functions and data in a DLL are loaded and linked at run time when they are referenced by a Windows application or other DLLs.
DMA	Direct memory access. A method by which data can be transferred to/from computer memory from/to a device or memory on the bus while the processor does something else. DMA is the fastest method of transferring data to/from computer memory.
DOS	Disk Operating System
driver	software that controls a specific hardware device such as a DAQ device or a GPIB interface device
DSP	digital signal processing
DTEMP	direct temperature mode
E	
EEPROM	Electrically erasable programmable read-only memory. ROM that can be erased with an electrical signal and reprogrammed.
EGA	enhanced graphics adapter

EISA	Extended Industry Standard Architecture
EPP	enhanced parallel port
excitation	voltage or current supplied to a sensor
external trigger	a voltage pulse from an external source that triggers an event such as A/D conversion

G

gain	the factor by which a signal is amplified, sometimes expressed in decibels
GF	gauge factor

H

HDLC	high-level data link control
Hz	hertz

I

IBM	International Business Machines
IC	integrated circuit
IEEE	Institute of Electrical and Electronics Engineers
interrupt	a computer signal indicating that the CPU should suspend its current task to service a designated activity
I/O	input/output
IRQ	interrupt request
ISA	Industry Standard Architecture

K

kS	1,000 samples
Kword	1,024 words of memory

L

Lab/1200 device	refers to the DAQCard-1200, DAQPad-1200, Lab-PC+, Lab-PC-1200, Lab-PC-1200AI, PCI-1200, and SCXI-1200
LED	light-emitting diode
library	A file containing compiled object modules, each comprised of one or more functions, that can be linked to other object modules that make use of these functions. <code>nidaqmsc.lib</code> is a library that contains NI-DAQ functions. The NI-DAQ function set is broken down into object modules so that only the object modules that are relevant to your application are linked in, while those object modules that are not relevant are not linked.
LPM device	refers to the PC-LPM-16 and PC-LPM-16PnP
LSB	least significant bit
LVDT	linear variable differential transformer. A transformer-based sensor used to measure linear displacement.

M

MB	megabytes of memory
MIO	multifunction I/O
MIO device	refers to the multifunction I/O devices that have <i>MIO</i> in their names, such as the AT-MIO-16 and NEC-MIO-16E-4
MS	million samples
MTEMP	multiplexed temperature mode

multidrop	refers to a serial network with multiple devices
mux	multiplexer; a switching device with multiple inputs that sequentially connects each of its inputs to its output, typically at high speeds, in order to measure several signals with a single analog input channel.

N

N/A	not applicable
NB	NuBus
NC	not connected
NI-DAQ	refers to the NI-DAQ software for PC compatibles unless otherwise noted
NRSE	nonreferenced single-ended mode

O

oscillator	a circuit or device that produces a sine or square wave output
output settling time	the amount of time required for the analog output voltage to reach its final value within specified limits

P

PGIA	programmable-gain instrumentation amplifier
phase-shift	the angular difference between identical reference points in two oscillating signals
port	a digital port, consisting of four or eight lines of digital input and/or output
posttriggering	the technique used on a DAQ device to acquire a programmed number of samples after trigger conditions are met
ppm	parts per million
pretriggering	the technique used on a DAQ device to keep a continuous buffer filled with data, so that when the trigger conditions are met, the sample includes the data leading up to the trigger condition

programmed I/O	the standard method a CPU uses to access an I/O device—each byte of data is read or written by the CPU
pts	points
PXI	PCI eXtensions for Instrumentation. PXI is an open specification that builds off the CompactPCI specification by adding instrumentation-specific features

R

RAM	random-access memory
RC	resistance-capacitor
Remote SCXI	refers to an SCXI configuration where either an SCXI-2000 chassis or an SCXI-2400 remote communications module is connected to the serial port of your computer
REQ	request
resolution	The smallest signal increment that can be detected by a measurement system. Resolution can be expressed in bits, in proportions, or in percent of full scale. For example, a system has 12-bit resolution, one part in 4,096 resolution, and 0.0244% of full scale.
resolver	transformer-based sensor for measuring absolute angular displacement over 360 degrees. Measurement is continuous for any number of turns. The simultaneous conditioning of a sine and a cosine signal required.
R_g	gauge resistance
R_L	line resistance
RMA	return material authorization
ROM	read-only memory
R_{SCAL}	gauge resistance
RSE	referenced single-ended
RTD	resistance temperature detector—a metallic probe that measures temperature based upon its coefficient of resistivity

RTSI	real-time system integration (bus). The National Instruments timing bus that connects DAQ devices directly, by means of connectors on top of the devices, for precise synchronization of functions.
RVDT	rotary variable differential transformer. A transformer-based sensor used to measure absolute angular displacement. Their measurement range is typically between ± 30 and ± 70 degrees of rotation.
S	
s	seconds
S	samples
Sample-and-Hold (S/H)	a circuit that acquires and stores an analog voltage on a capacitor for a short period of time
scan	One or more analog or digital input samples. Typically, the number of input samples in a scan is equal to the number of channels in the input group. For example, one pulse from the scan clock produces one scan which acquires one new sample from every analog input channel in the group.
scan rate	The number of scans per second. For example, a scan rate of 10 Hz means sampling each channel 10 times per second.
SCXI	Signal Conditioning eXtensions for Instrumentation—the National Instruments product line for conditioning low-level signals within an external chassis near sensors so only high-level signals are sent to DAQ devices in the noisy PC environment
SCXI analog input module	refers to the SCXI-1100, SCXI-1102, SCXI-1112, SCXI-1120, SCXI-1121, SCXI-1122, SCXI-1125, SCXI-1140, SCXI-1141, SCXI-1142, and SCXI-1143
SCXI analog output module	refers to the SCXI-1124
SCXI chassis	refers to the SCXI-1000, SCXI-1000DC, SCXI-1001, and SCXI-2000
SCXI communication module	refers to the SCXI-2400
SCXI digital module	refers to the SCXI-1160, SCXI-1161, SCXI-1162, SCXI-1162HV, SCXI-1163, and SCXI-1163R

SCXI DAQ module	refers to the SCXI-1200
SDK	software development kit
self-calibrating	a property of a DAQ device that has an extremely stable onboard reference and calibrates its own A/D and D/A circuits without manual adjustments by the user
serial mode	the mode by which SCXI-116X modules communicate digital information serially rather than in parallel
SE (single-ended) inputs	an analog input that is measured with respect to a common ground
SPDT	single-pole double-throw
S/s	samples per second—used to express the rate at which a DAQ device samples an analog signal
software trigger	A programmed event that triggers an event such as data acquisition.
STC	System Timing Controller
synchronous	(1) Hardware—A property of an event that is synchronized to a reference clock. (2) Software—A property of a function that begins an operation and returns only when the operation is complete.
T	
thermocouple	a temperature sensor created by joining two dissimilar metals. The junction produces a small voltage as a function of temperature.
TTL	transistor-transistor logic
U	
unipolar	A signal range that is always positive (for example, 0 to +10 V).

V

V volts

VDC volts direct current

V_r $(V_{IN}/V_{EX})_{\text{strained}} - (V_{IN}/V_{EX})_{\text{unstrained}}$

V_{rms} volts, root mean square

Index

A

- amplifier output referencing mode. *See* signal referencing modes.
- analog circuitry for RTDs
 - analog input channels
 - description, 4-24
 - sense and current output channel associations (table), 4-24
 - SCXI-1122 circuitry, 4-23
- analog input modes
 - DIFF
 - configuration (table), 3-52
 - description, 3-53
 - NRSE
 - configuration (table), 3-52
 - description, 3-53
 - recommended modes for DAQ devices, 3-3
 - RSE
 - configuration (table), 3-52
 - description, 3-53
- analog input modules
 - overview, 1-17
 - SCXI signal routing (figure), 1-18
- analog module configuration, 3-2
 - floating signal sources, 3-3
 - ground-referenced signals, 3-3
 - SCXI-1100, 3-4
 - SCXI-1102/B/C, 3-7
 - SCXI-1112, 3-8
 - SCXI-1120/D, 3-8, 3-9
 - SCXI-1121, 3-14
 - SCXI-1122, 3-23
 - SCXI-1124, 3-26
 - SCXI-1125, 3-28
 - SCXI-1126, 3-29
 - SCXI-1140, 3-29
 - SCXI-1141, 3-32

- SCXI-1520, 3-34
- analog output channel signal connections for SCXI-1124, 4-28
 - connecting DAC channel as voltage output (figure), 4-29
 - current loop connection, load and external supply grounded (figure), 4-31
 - DAC channel connection as current output
 - external loop supply (figure), 4-30
 - internal loop supply (figure), 4-29
- analog output modules, 1-19

B

- breakout connector, A-4

C

- cable assemblies, 1-14
 - attaching to SCXI module and chassis, 2-3
 - illustration, 2-4
 - problems and solutions, A-4
 - available cable assemblies (table), 1-14
- calibration hardware
 - RTD analog input channels, 4-25
- channels, synchronizing, 4-33
- chassis ground connections, 4-31
- cold-junction compensation, 4-5
- common questions and problems, A-2
- communication modes
 - digital SCXI modules, 3-37
 - parallel mode, 3-37
 - serial mode, 3-37
- ComponentWorks software, 1-16
- configuration
 - analog modules, 3-2
 - floating signal sources, 3-3
 - ground-referenced signal source, 3-3

- SCXI-1100, 3-4
 - SCXI-1102/B/C, 3-7
 - SCXI-1112, 3-8
 - SCXI-1120/D, 3-8, 3-9
 - SCXI-1121, 3-14
 - SCXI-1122, 3-23
 - SCXI-1124, 3-26
 - SCXI-1125, 3-28
 - SCXI-1126, 3-29
 - SCXI-1140, 3-29
 - SCXI-1141, 3-32
 - SCXI-1520, 3-34
 - digital modules, 3-36
 - communication modes, 3-37
 - parallel mode, 3-37
 - serial mode, 3-37
 - SCXI-1160, 3-38
 - SCXI-1161, 3-38
 - SCXI-1162, 3-39
 - SCXI-1162HV, 3-42
 - SCXI-1163, 3-44
 - SCXI-1163R, 3-47
 - SCXI-1200, 3-50
 - SCXI-2400, 3-56
 - module configuration, 3-1
 - accessing jumpers, 3-2
 - removing grounding screw (figure), 3-1
 - removing module cover (figure), 3-2
 - problems, A-2
 - SCXI-1000, SCXI-1000DC, and SCXI-1001 chassis, 3-58
 - SCXI-2000 chassis with serial communications, 3-58
 - software configuration, 3-59
 - example programs, 3-59
 - connector-and-shell assembly
 - definition, 1-13
 - overview, 4-7
 - current-loop receivers
 - SCXI-1100 module, 3-7
 - SCXI-1122 module, 3-25
 - Customer Education, B-1
- ## D
- DAQ modules, 1-13
 - See also* SCXI-1200 module
 - DAQ plug-in device or DAQCard
 - available devices, 1-13
 - connecting to SCXI systems
 - parallel port, 2-2
 - plug-in DAQ device or PC card, 2-3
 - RS-232 or RS-485 serial port, 2-6
 - installation, 2-2
 - multichassis system with plug-in DAQ device, 1-14
 - differential input (DIFF) mode
 - configuration (table), 3-52
 - description, 3-53
 - MIO devices, 3-3
 - digital SCXI modules
 - communication modes, 3-37
 - parallel mode, 3-37
 - serial mode, 3-37
 - configuration, 3-36
 - SCXI-1160, 3-38
 - SCXI-1161, 3-38
 - SCXI-1162, 3-39
 - SCXI-1162HV, 3-42
 - SCXI-1163, 3-44
 - SCXI-1163R, 3-47
 - SCXI-1200, 3-50
 - SCXI-2400, 3-56
 - overview, 1-19
 - direct-mount terminal blocks (table), 1-9
 - documentation
 - conventions used in guide, *xi*
 - related documentation, *xiii*

E

- excitation channel signal connections, 4-22
 - connecting quarter-bridge strain gauge (figure), 4-23
- exceeding overvoltage protection or isolation rating (warning), 4-22
- excitation level, 4-22
- maximum load per excitation channel (table), 4-22
- using internal half-bridge completion, 4-23
- excitation level configuration
 - SCXI-1121, 3-19
 - SCXI-1520
 - excitation voltage ranges for configuration and gauge resistances (table), 4-15
- excitation mode configuration
 - SCXI-1121, 3-17
- excitation output channels, 4-25
 - four-wire scan connection (figure), 4-27
 - pros and cons of two-wire and four-wire connections (table), 4-28
 - series connection (figure), 4-27
 - shunt calibration, 4-25
 - voltage excitation channel, 4-25

F

- filtering
 - configuration and jumper settings
 - SCXI-1100 module, 3-5
 - SCXI-1120/D module, 3-11
 - SCXI-1121 module, 3-16
 - hardware filtering, 4-9
 - noise filtering for thermocouples, 4-9
 - RTD analog input channels, 4-25
- floating signal sources, 3-3
- fuse
 - blown, A-3

G

- gain
 - configuration and jumper settings
 - SCXI-1120/D module, 3-9
 - SCXI-1121 module, 3-15
 - SCXI-1140 module, 3-31
 - setting gain for continuous data acquisition, A-3
- ground connections, 4-31
- ground-referenced signals
 - description, 3-3
 - problems and solutions, A-2

H

- hardware filtering, 4-9

I

- input modes. *See* analog input modes.
- input signal referencing
 - SCXI-1100 module, 3-4
- installation
 - connecting SCXI systems to DAQ device or computer, 2-2
 - attaching cable assembly to SCXI module and chassis, 2-3
 - parallel port, 2-2
 - plug-in DAQ device or PC card, 2-3
 - RS-232 or RS-485 serial port, 2-6
 - DAQ devices, 2-2
 - SCXI modules, 2-2
 - software installation, 2-1
- instrumentation amplifier output referencing mode
 - SCXI-1140 module, 3-30
- isolation amplifier for RTDs, 4-25

J

- jumper settings

See specific modules

jumpers

accessing, 3-2

L

LabVIEW software

addressing SCXI-1200 analog input channels, A-2

overview, 1-15

problems with SCXI-1100 module, A-2

LabWindows/CVI software, 1-15

LVDTs

connecting to, 4-32

M

manual. See documentation.

MISO signal

connecting to SERDATOUT pin

SCXI-1120/D module, 3-14

SCXI-1121 module, 3-23

SCXI-1140 module, 3-32

multichannel scanning, 1-18

multichassis system with plug-in DAQ device, 1-14

multiplexed mode of operation, 1-17

N

National Instruments Web support, B-1

NI Developer Zone, B-1

NI-DAQ driver software, 1-15

noise reduction for thermocouples, 4-9

nonreferenced single-ended (NRSE) mode

description, 3-53

Lab devices, 3-3

SCXI-1200 configuration (table), 3-52

NRSE. See nonreferenced single-ended (NRSE) mode.

O

output signal referencing

SCXI-1120/D module, 3-13

SCXI-1121 module, 3-23

SCXI-1140 module, 3-30

P

parallel communication modes

configuration and jumper settings

SCXI-1162 module, 3-40

SCXI-1163 module, 3-45

description, 3-37

parallel mode of operation, 1-17

parallel port connections

SCXI systems, 2-2

SCXI-1200 module, 3-50

PGIA output referencing modes

SCXI-1100 module, 3-6

polarity settings for SCXI-1200 module

analog I/O settings (table), 3-51

configuration, 3-54

factory settings, 3-51

jumper settings (table), 3-54

problems and solutions, A-1

R

referenced single-ended (RSE) mode

description, 3-53

Lab devices, 3-3

SCXI-1200 configuration (table), 3-52

relay multiplexer for RTDs, 4-24

relays for SCXI-1122

avoiding mechanical wear on (note), 3-25

requirements for getting started, 1-3

Resistance-Temperature Detectors (RTDs).

See RTDs.

resolvers

connecting to, 4-35

- RS-232 or RS-485 serial port
 - connecting SCXI systems, 2-6
 - problems and solutions, A-2
- RSE mode. *See* referenced single-ended (RSE) mode.
- RTDs, 4-19
 - analog circuitry, 4-23
 - analog input channels, 4-24
 - sense and current output channel associations (table), 4-24
 - analog output channel signal connections to SCXI-1124, 4-28
 - connecting to SCXI-1121 module (figure), 4-21
 - connecting to SCXI-1320 terminal block, 4-19
 - excitation channel signal connections on SCXI-1122, 4-22
 - excitation output channels, 4-25
 - four-wire scan connection (figure), 4-27
 - pros and cons of two-wire and four-wire connections (table), 4-28
 - series connection (figure), 4-27
 - verifying high-common-mode voltage (warning), 4-19
- RVDTs
 - connecting to, 4-32
- S**
- scanning
 - multichannel scanning, 1-18
 - techniques for SCXI-1122 module, 3-25
- SCXI
 - components. *See* SCXI components.
 - configurations (figure), 1-2
 - overview, 1-1
 - requirements for getting started, 1-3
- SCXI cable assemblies. *See* cable assemblies.
- SCXI chassis
 - configuration, 3-58
 - description, 1-4
 - ground connections, 4-31
 - SCXI multichassis system with plug-in DAQ device, 1-14
 - SCXI-1000, SCXI-1000DC, and SCXI-1001 chassis, 3-58
 - SCXI-2000 chassis with serial communications, 3-58
 - signal routing (figure), 1-5
- SCXI components, 1-3
 - cable assemblies, 1-14
 - DAQ modules, 1-13
 - DAQ plug-in devices and PC cards, 1-13
 - multichassis system with plug-in DAQ device, 1-14
 - optional software, 1-15
 - SCXI chassis, 1-4
 - SCXI modules, 1-5
 - terminal blocks, 1-7
- SCXI modules
 - available modules (table), 1-6
 - connecting to DAQ device or computer, 2-2
 - installation, 2-2
 - overview, 1-5
 - SCXI module and connector compatibility (table), 4-1
 - troubleshooting and common questions, A-1
- SCXI multichassis system with plug-in DAQ device, 1-14
- SCXI operation, 1-17
 - analog input modules, 1-17
 - analog output modules, 1-19
 - digital modules, 1-19
 - signal routing (figure), 1-18
- SCXI Slot 0, 1-18
- SCXI-1000 chassis
 - configuring, 3-58
- SCXI-1000DC chassis

- configuring, 3-58
- SCXI-1001 chassis
 - configuring, 3-58
- SCXI-1100 module
 - configuration and jumper settings, 3-4
 - filtering, 3-5
 - input signal referencing mode, 3-4
 - PGA output referencing modes, 3-6
 - when to change factory settings, 3-4
 - problems and solutions
 - cable assembly, A-4
 - ground-referenced signals, A-2
 - LabVIEW software, A-2
 - setting gain for continuous gain acquisition, A-3
 - thermocouples, A-3
 - thermocouples, 4-7
- SCXI-1102/B/C module
 - configuration and jumper settings, 3-7
 - thermocouples, 4-8
- SCXI-1112 module
 - configuration, 3-8
 - thermocouples, 4-8
- SCXI-1120/D module
 - configuration and jumper settings, 3-8, 3-9
 - connecting MISO signal to SERDATOUT pin, 3-14
 - filtering, 3-11
 - gains, 3-9
 - signal output referencing, 3-13
 - temperature sensor signal routing, 3-13
 - when to change factory settings, 3-9
 - filtering
 - filter jumper allocation (table), 3-12
 - filter jumper allocations (table), 3-11
 - gain
 - gain jumper allocation (table), 3-9
 - gain jumper positions (table), 3-10
 - temperature sensor signal routing
 - signal referencing jumper configuration (table), 3-14
 - thermocouples, 4-8
- SCXI-1121 module
 - configuration and jumper settings, 3-14
 - connecting MISO signal to SERDATOUT pin, 3-23
 - enabling half-bridge completion network, 3-21
 - excitation levels, 3-19
 - excitation mode, 3-17
 - filtering, 3-16
 - gain selection, 3-15
 - signal output referencing, 3-23
 - when to change factory settings, 3-15
 - connecting to RTDs (figure), 4-21
 - thermocouples, 4-8
- SCXI-1122 module
 - configuration and jumper settings, 3-23
 - grounding, shielding, and reference mode selection, 3-25
 - current-loop receivers, 3-25
 - excitation channel signal connections, 4-22
 - connecting quarter-bridge strain gauge (figure), 4-23
 - exceeding overvoltage protection or isolation rating (warning), 4-22
 - excitation level, 4-22
 - maximum load per excitation channel (table), 4-22
 - using internal half-bridge completion, 4-23
 - overview and features, 3-23
 - scanning techniques, 3-25
 - thermocouples, 4-8
- SCXI-1124 module
 - analog output channel signal connections, 4-28
 - connecting DAC channel as voltage output (figure), 4-29

- current loop connection, load and external supply grounded (figure), 4-31
- DAC channel connection as current output
 - external loop supply (figure), 4-30
 - internal loop supply (figure), 4-29
- configuration and jumper settings, 3-26
 - setting for specific DAQ device, 3-27
 - single or multichassis system, 3-27
- SCXI-1125 module
 - configuration, 3-28
 - thermocouples, 4-8
- SCXI-1126 module
 - configuring, 3-29
- SCXI-1140 module
 - configuration and jumper settings, 3-29
 - connecting MISO signal to SERDATOUT pin, 3-32
 - DAQ device connections in multiple-module systems, 3-29
 - gain selection, 3-31
 - instrumentation amplifier output referencing mode, 3-30
 - signal referencing mode, 3-30
 - user-configurable jumpers and DIP switches, 3-29
 - connecting to DAQ device, A-4
- SCXI-1141/1142/1143 module configuration and jumper settings, 3-32
 - chassis jumper configurations (table), 3-33
 - grounding and shielding jumper configurations (table), 3-34
 - when to change factory settings (note), 3-32
- SCXI-1160 module configuration and jumper settings, 3-38
- SCXI-1161 module configuration and jumper settings, 3-38
- SCXI-1162 module
 - configuration and jumper settings, 3-39
 - device type selection, 3-41
 - parallel lines selection, 3-40
 - parallel or serial mode selection, 3-40
 - when to change factory settings (note), 3-39
 - problems and solutions, A-5
- SCXI-1162HV module configuration and jumper settings, 3-42
- SCXI-1163 module
 - configuration and jumper settings, 3-44
 - device type selection, 3-45
 - serial or parallel mode selection, 3-45
 - when to change factory settings (note), 3-45
 - problems and solutions, A-5
- SCXI-1163R module configuration and jumper settings, 3-47
- SCXI-1180 feedthrough panel, 3-56
- SCXI-1181 breadboard module, 3-56
- SCXI-1200 module
 - analog I/O configuration, 3-51
 - analog input configuration, 3-52
 - DIFF input, 3-53
 - input configurations (table), 3-52
 - NRSE input, 3-53
 - RSE input, 3-53
 - analog input polarity and range, 3-54
 - analog I/O settings (table), 3-51
 - factory settings, 3-51
 - jumper settings (table), 3-54
 - analog output configuration, 3-52
 - front connector pin assignments (figure), 3-55
 - LabVIEW problems, A-2
 - module configuration, 3-51
 - overview, 3-50
 - parallel port interface, 3-50
- SCXI-1320 terminal block (figure), 4-20
- SCXI-1321 terminal block (figure), 4-10

- SCXI-1520 module
 - configuration, 3-34
 - NI-DAQ functions applicable to SCXI-1520 (table), 3-35
 - strain gauges, 4-15
 - excitation voltage ranges for configuration and gauge resistances (table), 4-15
- SCXI-2000 chassis with serial communications
 - baud rate and address configuration, 3-58
 - overview, 3-58
- SCXI-2400 serial communications module
 - baud rate and address configuration, 3-57
 - overview, 3-56
- SERDATOUT pin
 - connecting to MISO signal
 - SCXI-1120/D module, 3-14
 - SCXI-1121 module, 3-23
 - SCXI-1140 module, 3-32
 - pullup resistors connected to, 3-42
- serial communication mode
 - configuration
 - SCXI-1162 module, 3-40
 - SCXI-1163 module, 3-45
 - description, 3-37
- serial communications modules
 - SCXI-2000 chassis with serial communications, 3-58
 - SCXI-2400 serial communications module, 3-56
- signal referencing modes
 - input signal referencing
 - SCXI-1100 module, 3-4
 - instrumentation amplifier negative input
 - SCXI-1140 module, 3-30
 - output signal referencing
 - SCXI-1120/D module, 3-13
 - SCXI-1121 module, 3-23
 - SCXI-1140 module, 3-30
- signal wire connections, 4-1
 - connector-and-shell assemblies, 4-7
 - SCXI module and connector compatibility (table), 4-1
 - terminal blocks, 4-4
 - onboard temperature sensors for cold-junction compensation, 4-5
 - opening SCXI-13XX terminal block, 4-6
 - SCXI-13XX terminal blocks, 4-4
 - TBX terminal blocks, 4-4
- signals
 - floating single sources, 3-3
 - ground-referenced signal source, 3-3, A-2
 - onboard resources reserved by SCXI (table), A-5
- single-channel readings, 1-17
- Slot 0, 1-18
- software
 - configuration, 3-59
 - example programs, 3-59
 - installation, 2-1
 - optional software, 1-15
- strain gauges, 4-9
 - connecting half-bridge gauge to SCXI-1321 terminal block (figure), 4-10
 - full-bridge configurations (figure), 4-14, 4-16, 4-17, 4-18
 - half-bridge configurations (figure), 4-13
 - quarter-bridge configurations (figure), 4-12
 - requirements for using, 4-9
 - SCXI-1520, 4-15
 - excitation voltage ranges for configuration and gauge resistances (table), 4-15
 - verifying high-common-mode voltage (warning), 4-9
- system integration, B-1

T

TBX terminal blocks. *See* terminal blocks.

technical support resources, B-1

temperature sensors

 cold-junction compensation, 4-5

 RTD analog input channels, 4-24

 signal routing

 SCXI-1120/D, 3-13

terminal blocks, 4-4

 connecting half-bridge gauge to
 SCXI-1321 terminal block (figure),
 4-10

 description, 1-7

 direct-mount (table), 1-9

 onboard temperature sensors for
 cold-junction compensation, 4-5

 opening SCXI-13XX terminal block, 4-6

 options (figure), 1-8

 SCXI-13XX terminal blocks, 4-4

 TBX terminal blocks

 available TBX terminal blocks
 (table), 1-12

 cabled to SCXI module (figure), 4-4

 compatibility with SCXI modules
 (table), 4-5

 overview, 4-4

thermocouples, 4-7

 noise and filtering, 4-9

 problems and solutions, A-3

 SCXI-1100, 4-7

 SCXI-1102/B/C, 4-8

 SCXI-1112, 4-8

 SCXI-1120/D, SCXI-1121, SCXI-1122,
 and SCXI-1125 modules, 4-8

transducers, 4-7

 chassis ground connections, 4-31

 RTDs, 4-19

 analog circuitry, 4-23

 analog input channels, 4-24

 analog output channel signal
 connections to SCXI-1124, 4-28

 connecting to SCXI-1121 module
 (figure), 4-21

 connecting to SCXI-1320 terminal
 block, 4-19

 excitation channel signal connections
 on SCXI-1122, 4-22

 excitation output channels, 4-25

 verifying high-common-mode
 voltage (warning), 4-19

strain gauges, 4-9

 connecting half-bridge gauge to
 SCXI-1321 terminal block
 (figure), 4-10

 full-bridge configuration (figure),
 4-14, 4-16, 4-17, 4-18

 half-bridge configuration (figure),
 4-13

 quarter-bridge configuration I
 (figure), 4-12

 quarter-bridge configuration II
 (figure), 4-12

 requirements for using, 4-9

 verifying high-common-mode
 voltage (warning), 4-9

thermocouples, 4-7

 noise and filtering, 4-9

 problems and solutions, A-3

 SCXI-1100 module, 4-7

 SCXI-1102/B/C module, 4-8

 SCXI-1112 module, 4-8

 SCXI-1120/D, SCXI-1121,
 SCXI-1122, and SCXI-1125
 modules, 4-8

troubleshooting SCXI problems, A-1

W

Web support, B-1

worldwide technical support, B-2